

DEK 

ASM 

Grid-Lok

Automated High Density Tooling

Grid-Lok

Selection guide

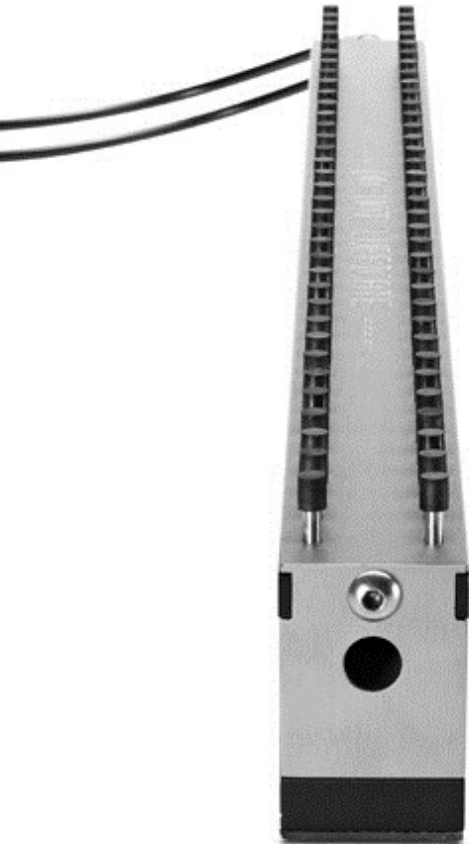

Stencil printers

Placement machines

Flying probe testers

AOI equipment

Grid-Lok spares

Stencil printer Grid-Lok selection guide

Click manufacturer to view the available Grid-Lok options

[Assembleon](#)[ASM DEK](#)[Desen](#)[Ekra](#)[Ersa](#)[Essemtech](#)[GKG](#)[Milara](#)[Minami](#)[Mirai](#)[MPM](#)[Panasonic](#)[Reprint](#)[Samsung](#)[Speedprint](#)[Yamaha](#)

Pick and place Grid-Lok selection guide

Click manufacturer to view the available Grid-Lok options

[ASM SIPLACE](#)[Assembleon](#)[Casio](#)[Dima](#)[Fuji](#)[I-Pulse](#)[Juki](#)[Mimot](#)[Mirae](#)[Panasonic](#)[Samsung](#)[Sanyo](#)[Universal](#)[Yamaha](#)

Flying probe testers Grid-Lok selection guide

Click manufacturer to view the available Grid-Lok options

Itochu-Takaya

SPEA



AOI machines Grid-Lok selection guide

Click manufacturer to view the available Grid-Lok options

Viscom



Grid-Lok Spares selection guide

Click category to view the available Grid-Lok options

Top caps

Pin repair kits

Fittings

Sensors

Controllers

Pin-Lok (pin in paste)

Others



Assembleon printers Grid-Lok selection guide

Click machine type to view the available Grid-Lok options



MCP series



ASM DEK Grid-Lok selection guide

Click machine type to view the available Grid-Lok options



265 series

Infinity

Horizon series

Galaxy

Europa

All DEK with ProFlow



Desen printers Grid-Lok selection guide

Click machine type to view the available Grid-Lok options



DSP 1008

DSP 1068

DSP 2008

DSP 3008



Ekra Grid-Lok selection guide

Click machine type to view the available Grid-Lok options



E4 series

E5 series

X3 series

X4 series

X5 series

X6 series



Ersa printers Grid-Lok selection guide

Click machine type to view the available Grid-Lok options



Versaprint P1

Versaprint S1

Versaprint F1



Essemtec printers Grid-Lok selection guide

Click machine type to view the available Grid-Lok options



Tucano

SP 900



GKG printers Grid-Lok selection guide

Click machine type to view the available Grid-Lok options



G series (old)

Juki GKG printers



Milara Grid-Lok selection guide

Click machine type to view the available Grid-Lok options



TD series



Minami Grid-Lok selection guide

Click machine type to view the available Grid-Lok options



MK series



Mirai printers Grid-Lok selection guide

Click machine type to view the available Grid-Lok options



MP 800



Speedline MPM Grid-Lok selection guide

Click machine type to view the available Grid-Lok options



Accuflex

Accela

Momentum

MPM 125

UP 2000

AP 25

AP 25 Excel

AP 27

UP 1500

Q-Lok



Panasonic printers Grid-Lok selection guide

Click machine type to view the available Grid-Lok options



SP 18

SP 80

SP 60

SPG

SP 70



Reprint Grid-Lok selection guide

Click machine type to view the available Grid-Lok options

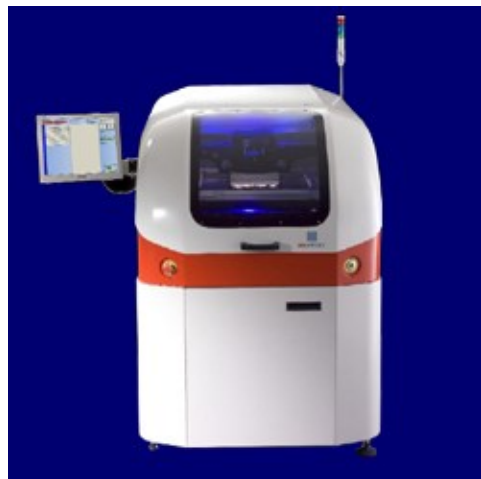

Mantis

R29 Spectrum



Samsung printers Grid-Lok selection guide

Click machine type to view the available Grid-Lok options



SMP series



Speedprint Grid-Lok selection guide

Click machine type to view the available Grid-Lok options



SP series

Yamaha printers Grid-Lok selection guide

Click machine type to view the available Grid-Lok options



YGP series

YSP series



ASM SIPLACE Grid-Lok selection guide

Click machine type to view the available Grid-Lok options



F series

HS50

C series

SX1, SX2

S series

HS60

D series

X2, X4, SX4



Assembleon Grid-Lok selection guide

Click machine type to view the available Grid-Lok options



GEM series

AX-201

AX-301

AX-501

I-FLEX single

I-FLEX dual



Casio Grid-Lok selection guide

Click machine type to view the available Grid-Lok options



7000-8000



Dima placement Grid-Lok selection guide

Click machine type to view the available Grid-Lok options



HP 110



Fuji placement Grid-Lok selection guide

Click machine type to view the available Grid-Lok options



NXT M3

NXT M3 dual lane

NXT M3 triple lane

NXT M6

NXT M6 dual lane



I-Pulse Grid-Lok selection guide

Click machine type to view the available Grid-Lok options



M series



Juki Grid-Lok selection guide

Click machine type to view the available Grid-Lok options

[FX 1](#)[FX 2](#)[FX 3](#)[KE](#)[JX](#)

Mimot Grid-Lok selection guide

Click machine type to view the available Grid-Lok options



Large table

Small table



Mirae Grid-Lok selection guide

Click machine type to view the available Grid-Lok options



MX200

MX400



Panasonic placement Grid-Lok selection guide

Click machine type to view the available Grid-Lok options



CM-402

CM-602

DT-401



Samsung placement Grid-Lok selection guide

Click machine type to view the available Grid-Lok options



CP 20

SM 421

CP 40

SM 481

CP 45

SM 482

CP 60

SM 471



Sanyo Grid-Lok selection guide

Click machine type to view the available Grid-Lok options



TCM 1000

TCM 1100



Universal Grid-Lok selection guide

Click machine type to view the available Grid-Lok options

[GX-11S](#)[GC-60D](#)[GC-30S](#)[GC-120Q](#)[AI-07S](#)[GX-11D](#)[AC-15S](#)[AC-90T](#)[GI-14D](#)[AC-30S](#)

Yamaha placement Grid-Lok selection guide

Click machine type to view the available Grid-Lok options

[YS24](#)[YS24X](#)[YS88](#)[YS100](#)[YS12](#)[YS12F](#)[YS12P](#)[YG12](#)[YG12F](#)[YG88R](#)[YG100R](#)[YV](#)

Itochu-Takaya Grid-Lok selection guide

Click machine type to view the available Grid-Lok options



APT-820-S

APT-8300

APT-8400

APT-8400-CE

APT-8400-CE-A

APT-9400-CE

APT-9400-CE-A

APT-9401-CE

APT-9401-CE-A

APT-9411-CE

APT-9411-CE-A

APT-9411-CE-A
(50mm special)

Grid-Lok Max™ for Itochu-Takaya flying probe testers



Viscom AOI Grid-Lok selection guide

Click machine type to view the available Grid-Lok options



Viscom AOI



Assembleon MCP printers

Kit content – tech specs

“n” PCB support modules

- module length: 12” or 18” (gold), 14” (silver)
- module width: 32mm
- module height (pins set): 66mm
- module height (pins reset): 45mm (gold), 49.5mm (silver)
- pins: 70 (gold 18”), 46 (gold 12”), 27 (silver)

“n” twin leashes with fittings

111_CTL – single table controller

006_MAN – manifold for 6 modules

001_DCP – Power supply 230V/24V

002_CON – Remote control unit

Air filter regulator

Tubes and air pipes

Note: Integration is done using pneumatic input from board clamps. 066_BLA is needed.

Grid-Lok Gold, 12” modules (recommended)



Grid-Lok Gold, 18” modules (recommended)



Grid-Lok Silver, 14” modules



Part No.	Description
GHD6612-1	Kit with one module
GHD6612-2	Kit with 2 modules
GHD6612-3	Kit with 3 modules
GHD6612-4	Kit with 4 modules
GHD6612-5	Kit with 5 modules
GHD6612-6	Kit with 6 modules
GHD6612	Golden HD single module

Part No.	Description
GHD6618-1	Kit with one module
GHD6618-2	Kit with 2 modules
GHD6618-3	Kit with 3 modules
GHD6618-4	Kit with 4 modules
GHD6618-5	Kit with 5 modules
GHD6618-6	Kit with 6 modules
GHD6618	Golden HD single module

Part No.	Description
GMD6614M	Silver manual single module
GMD6614-0	Conversion kit
GMD6614A-1	Kit with one module
GMD6614A-2	Kit with 2 modules
GMD6614A-3	Kit with 3 modules
GMD6614A-4	Kit with 4 modules
GMD6614A-5	Kit with 5 modules
GMD6614A-6	Kit with 6 modules
GMD6614A	Silver auto single module

DEK (ProFlow, 86mm)

Kit content – tech specs

- “n” PCB support modules
 - module length: 12” or 18” (gold), 14” (silver)
 - module width: 32mm
 - module height (pins set): 87mm
 - module height (pins reset): 45mm (gold), 49.5mm (silver)
 - pins: 70 (gold 18”), 46 (gold 12”), 27 (silver)
- “n” twin leashes with fittings
- 111_CTL – single table controller
- 006_MAN – manifold for 6 modules
- 001_DCP – Power supply 230V/24V
- 002_CON – Remote control unit
- Air filter regulator
- Tubes and air pipes

Note: Integration is done using pneumatic input from board clamps. 066_BLA is needed.

Grid-Lok Gold, 12” modules (recommended)



Grid-Lok Gold, 18” modules (recommended)



Grid-Lok Silver, 14” modules



Part No.	Description
GHD8712-1	Kit with one module
GHD8712-2	Kit with 2 modules
GHD8712-3	Kit with 3 modules
GHD8712-4	Kit with 4 modules
GHD8712-5	Kit with 5 modules
GHD8712-6	Kit with 6 modules
GHD8712	Golden HD single module

Part No.	Description
GHD8718-1	Kit with one module
GHD8718-2	Kit with 2 modules
GHD8718-3	Kit with 3 modules
GHD8718-4	Kit with 4 modules
GHD8718-5	Kit with 5 modules
GHD8718-6	Kit with 6 modules
GHD8718	Golden HD single module

Part No.	Description
GMD8714M	Silver manual single module
GMD8714-0	Conversion kit
GMD8714A-1	Kit with one module
GMD8714A-2	Kit with 2 modules
GMD8714A-3	Kit with 3 modules
GMD8714A-4	Kit with 4 modules
GMD8714A-5	Kit with 5 modules
GMD8714A-6	Kit with 6 modules
GMD8714A	Silver auto single module



DEK (squeegees, 81mm)

Kit content – tech specs

- “n” PCB support modules
 - module length: 12” or 18” (gold), 14” (silver)
 - module width: 32mm
 - module height (pins set): 81mm
 - module height (pins reset): 60mm (gold), 64.5mm (silver)
 - pins: 70 (gold 18”), 46 (gold 12”), 27 (silver)
- “n” twin leashes with fittings
- 111_CTL – single table controller
- 006_MAN – manifold for 6 modules
- 001_DCP – Power supply 230V/24V
- 002_CON – Remote control unit
- Air filter regulator
- Tubes and air pipes

Note: Integration is done using pneumatic input from board clamps.

Grid-Lok Gold, 12” modules (recommended)



Grid-Lok Gold, 18” modules (recommended)



Grid-Lok Silver, 14” modules



Part No.	Description
GHD8112-1	Kit with one module
GHD8112-2	Kit with 2 modules
GHD8112-3	Kit with 3 modules
GHD8112-4	Kit with 4 modules
GHD8112-5	Kit with 5 modules
GHD8112-6	Kit with 6 modules
GHD8112	Golden HD single module

Part No.	Description
GHD8118-1	Kit with one module
GHD8118-2	Kit with 2 modules
GHD8118-3	Kit with 3 modules
GHD8118-4	Kit with 4 modules
GHD8118-5	Kit with 5 modules
GHD8118-6	Kit with 6 modules
GHD8118	Golden HD single module

Part No.	Description
GMD8114M	Silver manual single module
GMD8114-0	Conversion kit
GMD8114A-1	Kit with one module
GMD8114A-2	Kit with 2 modules
GMD8114A-3	Kit with 3 modules
GMD8114A-4	Kit with 4 modules
GMD8114A-5	Kit with 5 modules
GMD8114A-6	Kit with 6 modules
GMD8114A	Silver auto single module



DEK (ProFlow, 86mm)

Kit content – tech specs

- “n” PCB support modules
 - module length: 12” or 18” (gold), 14” (silver)
 - module width: 32mm
 - module height (pins set): 86mm
 - module height (pins reset): 60mm (gold), 69.5mm (silver)
 - pins: 70 (gold 18”), 46 (gold 12”), 27 (silver)
- “n” twin leashes with fittings
- 111_CTL – single table controller
- 006_MAN – manifold for 6 modules
- 001_DCP – Power supply 230V/24V
- 002_CON – Remote control unit
- Air filter regulator
- Tubes and air pipes

Note: Integration is done using pneumatic input from board clamps.

Grid-Lok Gold, 12” modules (recommended)



Grid-Lok Gold, 18” modules (recommended)

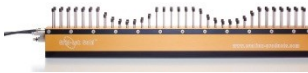

Grid-Lok Silver, 14” modules



Part No.	Description
GHD8612-1	Kit with one module
GHD8612-2	Kit with 2 modules
GHD8612-3	Kit with 3 modules
GHD8612-4	Kit with 4 modules
GHD8612-5	Kit with 5 modules
GHD8612-6	Kit with 6 modules
GHD8612	Golden HD single module

Part No.	Description
GHD8618-1	Kit with one module
GHD8618-2	Kit with 2 modules
GHD8618-3	Kit with 3 modules
GHD8618-4	Kit with 4 modules
GHD8618-5	Kit with 5 modules
GHD8618-6	Kit with 6 modules
GHD8618	Golden HD single module

Part No.	Description
GMD8614M	Silver manual single module
GMD8614-0	Conversion kit
GMD8614A-1	Kit with one module
GMD8614A-2	Kit with 2 modules
GMD8614A-3	Kit with 3 modules
GMD8614A-4	Kit with 4 modules
GMD8614A-5	Kit with 5 modules
GMD8614A-6	Kit with 6 modules
GMD8614A	Silver auto single module



Desen DSP-1008, 2008 & 3008 printers

Kit content – tech specs

- “n” PCB support modules
 - module length: 12” or 18”
 - module width: 32mm
 - module height (pins set): 50mm
 - module height (pins reset): 36.5mm
 - pins: 70 (gold 18”), 46 (gold 12”)
- “n” twin leashes with fittings
- 111_CTL – single table controller
- 006_MAN – manifold for 6 modules
- 001_DCP – Power supply 230V/24V
- 002_CON – Remote control unit
- Air filter regulator
- Tubes and air pipes

Note: Integration is done using 077_SBA (optical sensor).

Grid-Lok Gold, 12” modules

Part No.	Description
GHD5012-1	Kit with one module
GHD5012-2	Kit with 2 modules
GHD5012-3	Kit with 3 modules
GHD5012-4	Kit with 4 modules
GHD5012-5	Kit with 5 modules
GHD5012-6	Kit with 6 modules
GHD5012	Golden HD single module

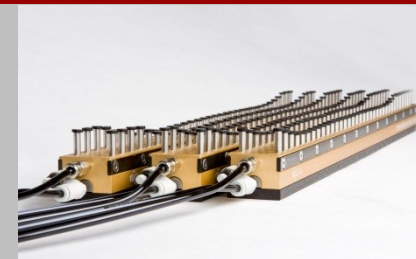

Grid-Lok Gold, 18” modules

Part No.	Description
GHD5018-1	Kit with one module
GHD5018-2	Kit with 2 modules
GHD5018-3	Kit with 3 modules
GHD5018-4	Kit with 4 modules
GHD5018-5	Kit with 5 modules
GHD5018-6	Kit with 6 modules
GHD5018	Golden HD single module



Note: Grid-Lok Silver is not available for this type of machine, due to the very low tooling height (50mm).



Desen DSP-1068 printers

Kit content – tech specs

- “n” PCB support modules
 - module length: 12” or 18” (gold), 14” (silver)
 - module width: 32mm
 - module height (pins set): 90mm
 - module height (pins reset): 63mm (gold), 73.5mm (silver)
 - pins: 70 (gold 18”), 46 (gold 12”), 27 (silver)
- “n” twin leashes with fittings
- 111_CTL – single table controller
- 006_MAN – manifold for 6 modules
- 001_DCP – Power supply 230V/24V
- 002_CON – Remote control unit
- Air filter regulator
- Tubes and air pipes

Note: Integration is done using pneumatic input from board clamps. 077_SBA optical sensor is needed.

Grid-Lok Gold, 12” modules (recommended)



Grid-Lok Gold, 18” modules (recommended)



Grid-Lok Silver, 14” modules



Part No.	Description
GHD9012-1	Kit with one module
GHD9012-2	Kit with 2 modules
GHD9012-3	Kit with 3 modules
GHD9012-4	Kit with 4 modules
GHD9012-5	Kit with 5 modules
GHD9012-6	Kit with 6 modules
GHD9012	Golden HD single module

Part No.	Description
GHD9018-1	Kit with one module
GHD9018-2	Kit with 2 modules
GHD9018-3	Kit with 3 modules
GHD9018-4	Kit with 4 modules
GHD9018-5	Kit with 5 modules
GHD9018-6	Kit with 6 modules
GHD9018	Golden HD single module

Part No.	Description
GMD9014M	Silver manual single module
GMD9014-0	Conversion kit
GMD9014A-1	Kit with one module
GMD9014A-2	Kit with 2 modules
GMD9014A-3	Kit with 3 modules
GMD9014A-4	Kit with 4 modules
GMD9014A-5	Kit with 5 modules
GMD9014A-6	Kit with 6 modules
GMD9014A	Silver auto single module



Ekra stencil printers

Kit content – tech specs

- “n” PCB support modules
 - module length: 12” or 18” (gold), 14” (silver)
 - module width: 32mm
 - module height (pins set): 87mm
 - module height (pins reset): 60mm (gold), 70.5mm (silver)
 - pins: 70 (gold 18”), 46 (gold 12”), 27 (silver)
- “n” twin leashes with fittings
- 111_CTL – single table controller
- 006_MAN – manifold for 6 modules
- 001_DCP – Power supply 230V/24V
- 002_CON – Remote control unit
- Air filter regulator
- Tubes and air pipes

Note: Integration is done using pneumatic input from board clamps. 087_BLA – Board lifters needed

Grid-Lok Gold, 12” modules (recommended)



Grid-Lok Gold, 18” modules (recommended)



Grid-Lok Silver, 14” modules



Part No.	Description
GHD8712-1	Kit with one module
GHD8712-2	Kit with 2 modules
GHD8712-3	Kit with 3 modules
GHD8712-4	Kit with 4 modules
GHD8712-5	Kit with 5 modules
GHD8712-6	Kit with 6 modules
GHD8712	Golden HD single module

Part No.	Description
GHD8718-1	Kit with one module
GHD8718-2	Kit with 2 modules
GHD8718-3	Kit with 3 modules
GHD8718-4	Kit with 4 modules
GHD8718-5	Kit with 5 modules
GHD8718-6	Kit with 6 modules
GHD8718	Golden HD single module

Part No.	Description
GMD8714M	Silver manual single module
GMD8714-0	Conversion kit
GMD8714A-1	Kit with one module
GMD8714A-2	Kit with 2 modules
GMD8714A-3	Kit with 3 modules
GMD8714A-4	Kit with 4 modules
GMD8714A-5	Kit with 5 modules
GMD8714A-6	Kit with 6 modules
GMD8714A	Silver auto single module



Ersa stencil printers

Kit content – tech specs

- “n” PCB support modules
 - module length: 12” or 18” (gold), 14” (silver)
 - module width: 32mm
 - module height (pins set): 98mm
 - module height (pins reset): 71mm (gold), 81.5mm (silver)
 - pins: 70 (gold 18”), 46 (gold 12”), 27 (silver)
- “n” twin leashes with fittings
- 111_CTL – single table controller
- 006_MAN – manifold for 6 modules
- 001_DCP – Power supply 230V/24V
- 002_CON – Remote control unit
- Air filter regulator
- Tubes and air pipes

Note: Integration is done using pneumatic input from board clamps.

Grid-Lok Gold, 12” modules (recommended)



Grid-Lok Gold, 18” modules (recommended)



Grid-Lok Silver, 14” modules



Part No.	Description
GHD9812-1	Kit with one module
GHD9812-2	Kit with 2 modules
GHD9812-3	Kit with 3 modules
GHD9812-4	Kit with 4 modules
GHD9812-5	Kit with 5 modules
GHD9812-6	Kit with 6 modules
GHD9812	Golden HD single module

Part No.	Description
GHD9818-1	Kit with one module
GHD9818-2	Kit with 2 modules
GHD9818-3	Kit with 3 modules
GHD9818-4	Kit with 4 modules
GHD9818-5	Kit with 5 modules
GHD9818-6	Kit with 6 modules
GHD9818	Golden HD single module

Part No.	Description
GMD9814M	Silver manual single module
GMD9814-0	Conversion kit
GMD9814A-1	Kit with one module
GMD9814A-2	Kit with 2 modules
GMD9814A-3	Kit with 3 modules
GMD9814A-4	Kit with 4 modules
GMD9814A-5	Kit with 5 modules
GMD9814A-6	Kit with 6 modules
GMD9814A	Silver auto single module



Essemtec Tucano & SP 900 printers

Kit content – tech specs

- “n” PCB support modules
 - module length: 12” or 18”
 - module width: 32mm
 - module height (pins set): 44mm
 - module height (pins reset): 30.5mm
 - pins: 70 (gold 18”), 46 (gold 12”)
- “n” twin leashes with fittings
- 111_CTL – single table controller
- 006_MAN – manifold for 6 modules
- 001_DCP – Power supply 230V/24V
- 002_CON – Remote control unit
- Air filter regulator
- Tubes and air pipes

Note: Integration is done using pneumatic input from board clamps.

Grid-Lok Gold, 12” modules

Part No.	Description
GHD4412-1	Kit with one module
GHD4412-2	Kit with 2 modules
GHD4412-3	Kit with 3 modules
GHD4412-4	Kit with 4 modules
GHD4412-5	Kit with 5 modules
GHD4412-6	Kit with 6 modules
GHD4412	Golden HD single module

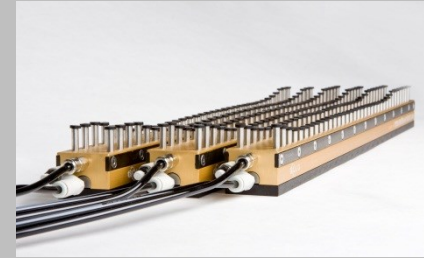

Grid-Lok Gold, 18” modules

Part No.	Description
GHD4418-1	Kit with one module
GHD4418-2	Kit with 2 modules
GHD4418-3	Kit with 3 modules
GHD4418-4	Kit with 4 modules
GHD4418-5	Kit with 5 modules
GHD4418-6	Kit with 6 modules
GHD4418	Golden HD single module

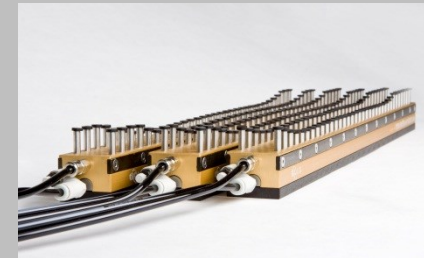

Note: Grid-Lok Silver is not available for this type of machine, due to the very low tooling height (44mm).



GKG G-series stencil printers

Kit content – tech specs

- “n” PCB support modules
 - module length: 12” or 18” (gold), 14” (silver)
 - module width: 32mm
 - module height (pins set): 90mm
 - module height (pins reset): 63mm (gold), 73.5mm (silver)
 - pins: 70 (gold 18”), 46 (gold 12”), 27 (silver)
- “n” twin leashes with fittings
- 111_CTL – single table controller
- 006_MAN – manifold for 6 modules
- 001_DCP – Power supply 230V/24V
- 002_CON – Remote control unit
- Air filter regulator
- Tubes and air pipes

Note: Integration is done using 077_SBA optical sensor.

Grid-Lok Gold, 12” modules (recommended)



Grid-Lok Gold, 18” modules (recommended)



Grid-Lok Silver, 14” modules



Part No.	Description
GHD9012-1	Kit with one module
GHD9012-2	Kit with 2 modules
GHD9012-3	Kit with 3 modules
GHD9012-4	Kit with 4 modules
GHD9012-5	Kit with 5 modules
GHD9012-6	Kit with 6 modules
GHD9012	Golden HD single module

Part No.	Description
GHD9018-1	Kit with one module
GHD9018-2	Kit with 2 modules
GHD9018-3	Kit with 3 modules
GHD9018-4	Kit with 4 modules
GHD9018-5	Kit with 5 modules
GHD9018-6	Kit with 6 modules
GHD9018	Golden HD single module

Part No.	Description
GMD9014M	Silver manual single module
GMD9014-0	Conversion kit
GMD9014A-1	Kit with one module
GMD9014A-2	Kit with 2 modules
GMD9014A-3	Kit with 3 modules
GMD9014A-4	Kit with 4 modules
GMD9014A-5	Kit with 5 modules
GMD9014A-6	Kit with 6 modules
GMD9014A	Silver auto single module



Milara TD printers

Kit content – tech specs

- “n” PCB support modules
 - module length: 12” or 18” (gold), 14” (silver)
 - module width: 32mm
 - module height (pins set): 64mm
 - module height (pins reset): 43mm (gold), 47.5mm (silver)
 - pins: 70 (gold 18”), 46 (gold 12”), 27 (silver)
- “n” twin leashes with fittings
- 111_CTL – single table controller
- 006_MAN – manifold for 6 modules
- 001_DCP – Power supply 230V/24V
- 002_CON – Remote control unit
- Air filter regulator
- Tubes and air pipes

Note: Integration is done using pneumatic input from board clamps. 064_BLA - Board lifters needed.

Grid-Lok Gold, 12” modules (recommended)



Grid-Lok Gold, 18” modules (recommended)



Grid-Lok Silver, 14” modules



Part No.	Description
GHD6412-1	Kit with one module
GHD6412-2	Kit with 2 modules
GHD6412-3	Kit with 3 modules
GHD6412-4	Kit with 4 modules
GHD6412-5	Kit with 5 modules
GHD6412-6	Kit with 6 modules
GHD6412	Golden HD single module

Part No.	Description
GHD6418-1	Kit with one module
GHD6418-2	Kit with 2 modules
GHD6418-3	Kit with 3 modules
GHD6418-4	Kit with 4 modules
GHD6418-5	Kit with 5 modules
GHD6418-6	Kit with 6 modules
GHD6418	Golden HD single module

Part No.	Description
GMD6414M	Silver manual single module
GMD6414-0	Conversion kit
GMD6414A-1	Kit with one module
GMD6414A-2	Kit with 2 modules
GMD6414A-3	Kit with 3 modules
GMD6414A-4	Kit with 4 modules
GMD6414A-5	Kit with 5 modules
GMD6414A-6	Kit with 6 modules
GMD6414A	Silver auto single module



Minami MK printers

Kit content – tech specs

- “n” PCB support modules
 - module length: 12” or 18” (gold), 14” (silver)
 - module width: 32mm
 - module height (pins set): 60mm
 - module height (pins reset): 39mm (gold), 43.5mm (silver)
 - pins: 70 (gold 18”), 46 (gold 12”), 27 (silver)
- “n” twin leashes with fittings
- 111_CTL – single table controller
- 006_MAN – manifold for 6 modules
- 001_DCP – Power supply 230V/24V
- 002_CON – Remote control unit
- Air filter regulator
- Tubes and air pipes

Note: Integration is done using pneumatic input from board clamps.

Grid-Lok Gold, 12” modules (recommended)



Grid-Lok Gold, 18” modules (recommended)



Grid-Lok Silver, 14” modules



Part No.	Description
GHD6012-1	Kit with one module
GHD6012-2	Kit with 2 modules
GHD6012-3	Kit with 3 modules
GHD6012-4	Kit with 4 modules
GHD6012-5	Kit with 5 modules
GHD6012-6	Kit with 6 modules
GHD6012	Golden HD single module

Part No.	Description
GHD6018-1	Kit with one module
GHD6018-2	Kit with 2 modules
GHD6018-3	Kit with 3 modules
GHD6018-4	Kit with 4 modules
GHD6018-5	Kit with 5 modules
GHD6018-6	Kit with 6 modules
GHD6018	Golden HD single module

Part No.	Description
GMD6014M	Silver manual single module
GMD6014-0	Conversion kit
GMD6014A-1	Kit with one module
GMD6014A-2	Kit with 2 modules
GMD6014A-3	Kit with 3 modules
GMD6014A-4	Kit with 4 modules
GMD6014A-5	Kit with 5 modules
GMD6014A-6	Kit with 6 modules
GMD6014A	Silver auto single module



Mirai MP-800 printers

Kit content – tech specs

- “n” PCB support modules
 - module length: 12” or 18”
 - module width: 32mm
 - module height (pins set): 50mm
 - module height (pins reset): 36.5mm
 - pins: 70 (gold 18”), 46 (gold 12”)
- “n” twin leashes with fittings
- 111_CTL – single table controller
- 006_MAN – manifold for 6 modules
- 001_DCP – Power supply 230V/24V
- 002_CON – Remote control unit
- Air filter regulator
- Tubes and air pipes

Note: Integration is done using 077_SBA (optical sensor).

Grid-Lok Gold, 12” modules

Part No.	Description
GHD5012-1	Kit with one module
GHD5012-2	Kit with 2 modules
GHD5012-3	Kit with 3 modules
GHD5012-4	Kit with 4 modules
GHD5012-5	Kit with 5 modules
GHD5012-6	Kit with 6 modules
GHD5012	Golden HD single module

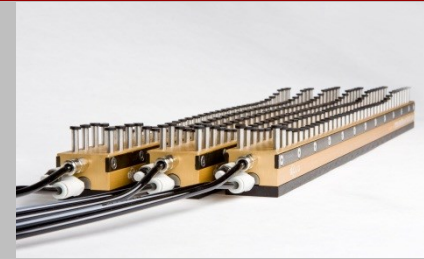

Grid-Lok Gold, 18” modules

Part No.	Description
GHD5018-1	Kit with one module
GHD5018-2	Kit with 2 modules
GHD5018-3	Kit with 3 modules
GHD5018-4	Kit with 4 modules
GHD5018-5	Kit with 5 modules
GHD5018-6	Kit with 6 modules
GHD5018	Golden HD single module

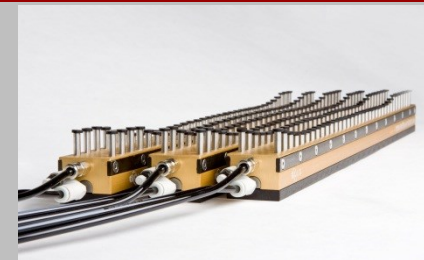

Note: Grid-Lok Silver is not available for this type of machine, due to the very low tooling height (50mm).



MPM Momentum, Accuflex, Accela

Kit content – tech specs

- “n” PCB support modules
 - module length: 12” or 18”
 - module width: 32mm
 - module height (pins set): 39mm
 - module height (pins reset): 25.5mm
 - pins: 70 (gold 18”), 46 (gold 12”)
- “n” twin leashes with fittings
- 111_CTL – single table controller
- 006_MAN – manifold for 6 modules
- 001_DCP – Power supply 230V/24V
- 002_CON – Remote control unit
- Air filter regulator
- Tubes and air pipes

Note: 077_SBA sensor is required, but it’s not included in the kit.

Grid-Lok Gold, 12” modules

Part No.	Description
GHD3912-1	Kit with one module
GHD3912-2	Kit with 2 modules
GHD3912-3	Kit with 3 modules
GHD3912-4	Kit with 4 modules
GHD3912-5	Kit with 5 modules
GHD3912-6	Kit with 6 modules
GHD3912	Golden HD single module



Grid-Lok Gold, 18” modules

Part No.	Description
GHD3918-1	Kit with one module
GHD3918-2	Kit with 2 modules
GHD3918-3	Kit with 3 modules
GHD3918-4	Kit with 4 modules
GHD3918-5	Kit with 5 modules
GHD3918-6	Kit with 6 modules
GHD3918	Golden HD single module

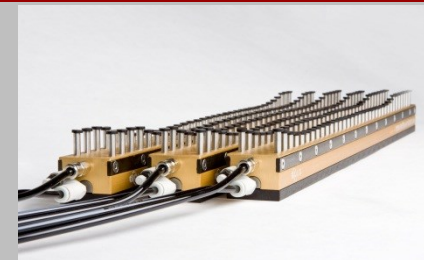

Note: Grid-Lok Silver is not available for this type of machine, due to the very low tooling height (39mm).



MPM UP2000 & AP series

Kit content – tech specs

- “n” PCB support modules
 - module length: 12” or 18” (gold), 14” (silver)
 - module width: 32mm
 - module height (pins set): 159mm
 - module height (pins reset): 132mm (gold), 142.5mm (silver)
 - pins: 70 (gold 18”), 46 (gold 12”), 27 (silver)

- “n” twin leashes with fittings
- 111_CTL – single table controller
- 006_MAN – manifold for 6 modules
- 001_DCP – Power supply 230V/24V
- 002_CON – Remote control unit
- Air filter regulator
- Tubes and air pipes

Note: Integration is done using pneumatic input from board clamps. MPM’s Y snugger tooling option or **Q-Lok** option is needed.



Grid-Lok Gold, 12” modules (recommended)



Grid-Lok Gold, 18” modules (recommended)



Grid-Lok Silver, 14” modules



Q-Lok

Part No.	Description
GHD1592-1	Kit with one module
GHD1592-2	Kit with 2 modules
GHD1592-3	Kit with 3 modules
GHD1592-4	Kit with 4 modules
GHD1592-5	Kit with 5 modules
GHD1592-6	Kit with 6 modules
GHD1592	Golden HD single module

Part No.	Description
GHD1598-1	Kit with one module
GHD1598-2	Kit with 2 modules
GHD1598-3	Kit with 3 modules
GHD1598-4	Kit with 4 modules
GHD1598-5	Kit with 5 modules
GHD1598-6	Kit with 6 modules
GHD1598	Golden HD single module

Part No.	Description
GMD1594M	Silver manual single module
GMD1594-0	Conversion kit
GMD1594A-1	Kit with one module
GMD1594A-2	Kit with 2 modules
GMD1594A-3	Kit with 3 modules
GMD1594A-4	Kit with 4 modules
GMD1594A-5	Kit with 5 modules
GMD1594A-6	Kit with 6 modules
GMD1594A	Silver auto single module

Panasonic SP printers

Kit content – tech specs

- “n” PCB support modules
 - module length: 12” or 18”
 - module width: 32mm
 - module height (pins set): 41mm
 - module height (pins reset): 27.5mm
 - pins: 70 (gold 18”), 46 (gold 12”)
- “n” twin leashes with fittings
- 111_CTL – single table controller
- 006_MAN – manifold for 6 modules
- 001_DCP – Power supply 230V/24V
- 002_CON – Remote control unit
- Air filter regulator
- Tubes and air pipes

Note: 077_SBA sensor is required, but it’s not included in the kit. 041_BLA – Board lifters might be required.

Grid-Lok Gold, 12” modules

Part No.	Description
GHD4112-1	Kit with one module
GHD4112-2	Kit with 2 modules
GHD4112-3	Kit with 3 modules
GHD4112-4	Kit with 4 modules
GHD4112-5	Kit with 5 modules
GHD4112-6	Kit with 6 modules
GHD4112	Golden HD single module



Grid-Lok Gold, 18” modules

Part No.	Description
GHD4118-1	Kit with one module
GHD4118-2	Kit with 2 modules
GHD4118-3	Kit with 3 modules
GHD4118-4	Kit with 4 modules
GHD4118-5	Kit with 5 modules
GHD4118-6	Kit with 6 modules
GHD4118	Golden HD single module



Note: Grid-Lok Silver is not available for this type of machine, due to the very low tooling height (41mm).



Reprint Mantis & R29 Spectrum

Kit content – tech specs

- “n” PCB support modules
 - module length: 12” or 18”
 - module width: 32mm
 - module height (pins set): 44mm
 - module height (pins reset): 30.5mm
 - pins: 70 (gold 18”), 46 (gold 12”)
- “n” twin leashes with fittings
- 111_CTL – single table controller
- 006_MAN – manifold for 6 modules
- 001_DCP – Power supply 230V/24V
- 002_CON – Remote control unit
- Air filter regulator
- Tubes and air pipes

Note: Integration is done using pneumatic input from board clamps.

Grid-Lok Gold, 12” modules

Part No.	Description
GHD4412-1	Kit with one module
GHD4412-2	Kit with 2 modules
GHD4412-3	Kit with 3 modules
GHD4412-4	Kit with 4 modules
GHD4412-5	Kit with 5 modules
GHD4412-6	Kit with 6 modules
GHD4412	Golden HD single module



Grid-Lok Gold, 18” modules

Part No.	Description
GHD4418-1	Kit with one module
GHD4418-2	Kit with 2 modules
GHD4418-3	Kit with 3 modules
GHD4418-4	Kit with 4 modules
GHD4418-5	Kit with 5 modules
GHD4418-6	Kit with 6 modules
GHD4418	Golden HD single module



Note: Grid-Lok Silver is not available for this type of machine, due to the very low tooling height (44mm).



Samsung SMP printers

Kit content – tech specs

- “n” PCB support modules
 - module length: 12” or 18” (gold), 14” (silver)
 - module width: 32mm
 - module height (pins set): 123mm
 - module height (pins reset): 96mm (gold), 106.5mm (silver)
 - pins: 70 (gold 18”), 46 (gold 12”), 27 (silver)
- “n” twin leashes with fittings
- 111_CTL – single table controller
- 006_MAN – manifold for 6 modules
- 001_DCP – Power supply 230V/24V
- 002_CON – Remote control unit
- Air filter regulator
- Tubes and air pipes

Note: Integration is done using pneumatic input from board clamps. 077_SBA – Optical sensor might be needed.

Grid-Lok Gold, 12” modules (recommended)



Grid-Lok Gold, 18” modules (recommended)



Grid-Lok Silver, 14” modules



Part No.	Description
GHD1232-1	Kit with one module
GHD1232-2	Kit with 2 modules
GHD1232-3	Kit with 3 modules
GHD1232-4	Kit with 4 modules
GHD1232-5	Kit with 5 modules
GHD1232-6	Kit with 6 modules
GHD1232	Golden HD single module

Part No.	Description
GHD1238-1	Kit with one module
GHD1238-2	Kit with 2 modules
GHD1238-3	Kit with 3 modules
GHD1238-4	Kit with 4 modules
GHD1238-5	Kit with 5 modules
GHD1238-6	Kit with 6 modules
GHD1238	Golden HD single module

Part No.	Description
GMD1234M	Silver manual single module
GMD1234-0	Conversion kit
GMD1234A-1	Kit with one module
GMD1234A-2	Kit with 2 modules
GMD1234A-3	Kit with 3 modules
GMD1234A-4	Kit with 4 modules
GMD1234A-5	Kit with 5 modules
GMD1234A-6	Kit with 6 modules
GMD1234A	Silver auto single module



Speedprint

Kit content – tech specs

- “n” PCB support modules
 - module length: 12” or 18” (gold), 14” (silver)
 - module width: 32mm
 - module height (pins set): 59mm
 - module height (pins reset): 45.5mm (gold), 47.5mm (silver)
 - pins: 70 (gold 18”), 46 (gold 12”), 27 (silver)
- “n” twin leashes with fittings
- 111_CTL – single table controller
- 006_MAN – manifold for 6 modules
- 001_DCP – Power supply 230V/24V
- 002_CON – Remote control unit
- Air filter regulator
- Tubes and air pipes

Note: Integration is done using pneumatic input from board clamps.

Grid-Lok Gold, 12” modules (recommended)



Grid-Lok Gold, 18” modules (recommended)



Grid-Lok Silver, 14” modules



Part No.	Description
GHD5912-1	Kit with one module
GHD5912-2	Kit with 2 modules
GHD5912-3	Kit with 3 modules
GHD5912-4	Kit with 4 modules
GHD5912-5	Kit with 5 modules
GHD5912-6	Kit with 6 modules
GHD5912	Golden HD single module

Part No.	Description
GHD5918-1	Kit with one module
GHD5918-2	Kit with 2 modules
GHD5918-3	Kit with 3 modules
GHD5918-4	Kit with 4 modules
GHD5918-5	Kit with 5 modules
GHD5918-6	Kit with 6 modules
GHD5918	Golden HD single module

Part No.	Description
GMD5914M	Silver manual single module
GMD5914-0	Conversion kit
GMD5914A-1	Kit with one module
GMD5914A-2	Kit with 2 modules
GMD5914A-3	Kit with 3 modules
GMD5914A-4	Kit with 4 modules
GMD5914A-5	Kit with 5 modules
GMD5914A-6	Kit with 6 modules
GMD5914A	Silver auto single module



Yamaha YSP printers

Kit content – tech specs

- “n” PCB support modules
 - module length: 12” or 18” (gold), 14” (silver)
 - module width: 32mm
 - module height (pins set): 67mm
 - module height (pins reset): 46mm (gold), 50.5mm (silver)
 - pins: 70 (gold 18”), 46 (gold 12”), 27 (silver)
- “n” twin leashes with fittings
- 111_CTL – single table controller
- 006_MAN – manifold for 6 modules
- 001_DCP – Power supply 230V/24V
- 002_CON – Remote control unit
- Air filter regulator
- Tubes and air pipes

Note: Integration is done using pneumatic input from board clamps. 067_BLA - Board lifters needed.

Grid-Lok Gold, 12” modules (recommended)



Grid-Lok Gold, 18” modules (recommended)



Grid-Lok Silver, 14” modules



Part No.	Description
GHD6712-1	Kit with one module
GHD6712-2	Kit with 2 modules
GHD6712-3	Kit with 3 modules
GHD6712-4	Kit with 4 modules
GHD6712-5	Kit with 5 modules
GHD6712-6	Kit with 6 modules
GHD6712	Golden HD single module

Part No.	Description
GHD6718-1	Kit with one module
GHD6718-2	Kit with 2 modules
GHD6718-3	Kit with 3 modules
GHD6718-4	Kit with 4 modules
GHD6718-5	Kit with 5 modules
GHD6718-6	Kit with 6 modules
GHD6718	Golden HD single module

Part No.	Description
GMD6714M	Silver manual single module
GMD6714-0	Conversion kit
GMD6714A-1	Kit with one module
GMD6714A-2	Kit with 2 modules
GMD6714A-3	Kit with 3 modules
GMD6714A-4	Kit with 4 modules
GMD6714A-5	Kit with 5 modules
GMD6714A-6	Kit with 6 modules
GMD6714A	Silver auto single module



Yamaha YGP printers

Kit content – tech specs

- “n” PCB support modules
 - module length: 12” or 18” (gold), 14” (silver)
 - module width: 32mm
 - module height (pins set): 64mm
 - module height (pins reset): 43mm (gold), 47.5mm (silver)
 - pins: 70 (gold 18”), 46 (gold 12”), 27 (silver)
- “n” twin leashes with fittings
- 111_CTL – single table controller
- 006_MAN – manifold for 6 modules
- 001_DCP – Power supply 230V/24V
- 002_CON – Remote control unit
- Air filter regulator
- Tubes and air pipes

Note: Integration is done using pneumatic input from board clamps. 064_BLA - Board lifters needed.

Grid-Lok Gold, 12” modules (recommended)



Grid-Lok Gold, 18” modules (recommended)



Grid-Lok Silver, 14” modules



Part No.	Description
GHD6412-1	Kit with one module
GHD6412-2	Kit with 2 modules
GHD6412-3	Kit with 3 modules
GHD6412-4	Kit with 4 modules
GHD6412-5	Kit with 5 modules
GHD6412-6	Kit with 6 modules
GHD6412	Golden HD single module

Part No.	Description
GHD6418-1	Kit with one module
GHD6418-2	Kit with 2 modules
GHD6418-3	Kit with 3 modules
GHD6418-4	Kit with 4 modules
GHD6418-5	Kit with 5 modules
GHD6418-6	Kit with 6 modules
GHD6418	Golden HD single module

Part No.	Description
GMD6414M	Silver manual single module
GMD6414-0	Conversion kit
GMD6414A-1	Kit with one module
GMD6414A-2	Kit with 2 modules
GMD6414A-3	Kit with 3 modules
GMD6414A-4	Kit with 4 modules
GMD6414A-5	Kit with 5 modules
GMD6414A-6	Kit with 6 modules
GMD6414A	Silver auto single module



ASM Siplace, F, C, S, HS50 machines

Kit content – tech specs

- “n” PCB support modules
 - module length: 14”
 - module width: 32mm
 - module height (pins set): 77mm
 - module height (pins reset): 60.5mm
 - pins: 27
- “n” twin leashes with fittings
- 111_CTL – single table controller
- 006_MAN – 6 station manifold
- 002_CON – Remote control unit
- 001_DCP – Power supply 230V/24V
- Air filter regulator
- Tubes and air pipes

Note: Kit is integrated using 077_SBA sensor, which is not included in the kit.

Grid-Lok Silver, 14” modules

Part No.	Description
GMD7714M	Silver manual single module
GMD7714-0	Conversion kit
GMD7714A-1	Kit with one module
GMD7714A-2	Kit with 2 modules
GMD7714A-3	Kit with 3 modules
GMD7714A	Silver auto single module



ASM Siplace SX1, SX2 and D series (machines with single tables)

Kit content – tech specs

- “n” PCB support modules
 - module length: 14”
 - module width: 32mm
 - module height (pins set): 97mm
 - module height (pins reset): 80.5mm
 - pins: 27
- “n” twin leashes with fittings
- 111_CTL – single table controller
- 006_MAN – 6 station manifold
- 002_CON – Remote control unit
- 001_DCP – Power supply 230V/24V
- Air filter regulator
- Tubes and air pipes

Note: Kit is integrated using 077_SBA sensor, which is not included in the kit.

Grid-Lok Silver, 14” modules

Part No.	Description
GMD9714M	Silver manual single module
GMD9714-0	Conversion kit
GMD9714A-1	Kit with one module
GMD9714A-2	Kit with 2 modules
GMD9714A-3	Kit with 3 modules
GMD9714A	Silver auto single module



ASM Siplace SX1, SX2 and D series (machines with two independent tables)

Kit content – tech specs

- “n” PCB support modules
 - module length: 14”
 - module width: 32mm
 - module height (pins set): 97mm
 - module height (pins reset): 80.5mm
 - pins: 27
- “n” twin leashes with fittings
- 211_CTL – dual table controller
- 2 x 006_MAN – 6 station manifolds
- 001_DCP – Power supply 230V/24V
- Air filter regulator
- Tubes and air pipes

Note: Kit is integrated using 077_SBA sensors (one for each table), which are not included in the kit.

Grid-Lok Silver, 14” modules

Part No.	Description
GMD9714M	Silver manual single module
GMD9714A2-0	Conversion kit
GMD9714A2-2	Kit with 2 modules (one per each table), dual controller
GMD9714A2-4	Kit with 4 modules (two per each table) , dual controller
GMD9714A2-6	Kit with 6 modules (three per each table), dual controller
GMD9714A	Silver auto single module

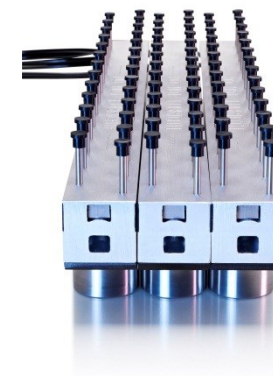

ASM Siplace HS60, X2, X4, SX4 (machines with four independent tables)

Kit content – tech specs

- “n” PCB support modules
 - module length: 14”
 - module width: 32mm
 - module height (pins set): 97mm
 - module height (pins reset): 80.5mm
 - pins: 27
- “n” twin leashes with fittings
- 411_CTL – 4-ways “quadro” controller
- 4 x 006_MAN – 6 station manifolds
- 001_DCP – Power supply 230V/24V
- Air filter regulator
- Tubes and air pipes

Note: Kit is integrated using 077_SBA sensors (one for each table), which are not included in the kit.

Grid-Lok Silver, 14” modules

Part No.	Description
GMD9714M	Silver manual single module
GMD9714A4-0	Conversion kit
GMD9714A4-4	Kit with 4 modules (one per each table), “quad” controller
GMD9714A4-8	Kit with 8 modules (two per each table) , “quad” controller
GMD9714A4-12	Kit with 12 modules (three per each table), “quad” controller
GMD9714A	Silver auto single module

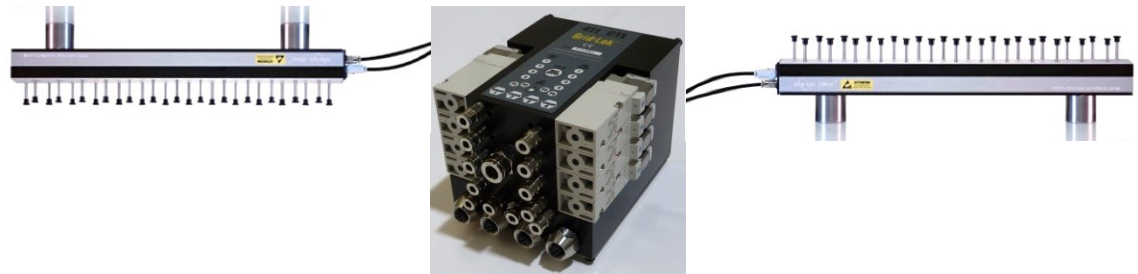

Assembleon I-FLEX single table machines

Kit content – tech specs

- “n” PCB support modules
 - module length: 14”
 - module width: 32mm
 - module height (pins set): 135mm
 - module height (pins reset): 118.5mm
 - pins: 27
- “n” twin leashes with fittings
- 111_CTL – single table controller
- 006_MAN – 6 station manifold
- 002_CON – Remote control unit
- 001_DCP – Power supply 230V/24V
- Air filter regulator
- Tubes and air pipes

Note: Kit is integrated using 077_SBA sensor, which is not included in the kit.

Grid-Lok Silver, 14” modules

Part No.	Description
GMD1354M	Silver manual single module
GMD1354-0	Conversion kit
GMD1354A-1	Kit with one module
GMD1354A-2	Kit with 2 modules
GMD1354A-3	Kit with 3 modules
GMD1354A	Silver auto single module



Assembleon I-FLEX dual (machines with two independent tables)

Kit content – tech specs

- “n” PCB support modules
 - module length: 14”
 - module width: 32mm
 - module height (pins set): 135mm
 - module height (pins reset): 118.5mm
 - pins: 27
- “n” twin leashes with fittings
- 211_CTL – dual table controller
- 2 x 006_MAN – 6 station manifolds
- 001_DCP – Power supply 230V/24V
- Air filter regulator
- Tubes and air pipes

Note: Kit is integrated using 077_SBA sensors (one for each table), which are not included in the kit.

Grid-Lok Silver, 14” modules

Part No.	Description
GMD1354M	Silver manual single module
GMD1354A2-0	Conversion kit
GMD1354A2-2	Kit with 2 modules (one per each table), dual controller
GMD1354A2-4	Kit with 4 modules (two per each table) , dual controller
GMD1354A2-6	Kit with 6 modules (three per each table), dual controller
GMD1354A	Silver auto single module



Assembleon GEM series

Kit content – tech specs

- “n” PCB support modules
 - module length: 14”
 - module width: 32mm
 - module height (pins set): 69mm
 - module height (pins reset): 52.5mm
 - pins: 27
- “n” twin leashes with fittings
- 111_CTL – single table controller
- 006_MAN – 6 station manifold
- 002_CON – Remote control unit
- 001_DCP – Power supply 230V/24V
- Air filter regulator
- Tubes and air pipes

Note: Kit is integrated using 077_SBA sensor, which is not included in the kit.

Grid-Lok Silver, 14” modules

Part No.	Description
GMD6914M	Silver manual single module
GMD6914-0	Conversion kit
GMD6914A-1	Kit with one module
GMD6914A-2	Kit with 2 modules
GMD6914A-3	Kit with 3 modules
GMD6914A	Silver auto single module



Assembleon AX-201

Kit content – tech specs

- “n” PCB support modules
 - module length: 14”
 - module width: 32mm
 - module height (pins set): 115mm
 - module height (pins reset): 98.5mm
 - pins: 27
- “n” twin leashes with fittings
- 111_CTL – single table controller
- 006_MAN – 6 station manifold
- 002_CON – Remote control unit
- 001_DCP – Power supply 230V/24V
- Air filter regulator
- Tubes and air pipes

Note: Kit is integrated using 077_SBA sensor, which is not included in the kit.

Grid-Lok Silver, 14” modules

Part No.	Description
GMD1154M	Silver manual single module
GMD1154-0	Conversion kit
GMD1154A-1	Kit with one module
GMD1154A-2	Kit with 2 modules
GMD1154A-3	Kit with 3 modules
GMD1154A	Silver auto single module

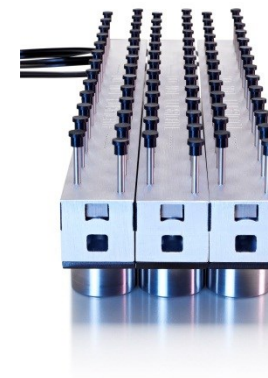

Assembleon AX-301 and AX-501

Kit content – tech specs

- “n” PCB support modules
 - module length: 18”
 - module width: 32mm
 - module height (pins set): 47mm
 - module height (pins reset): 33.5mm
 - pins: 70
- “n” twin leashes with fittings
- 111_CTL – single table controller
- 003_MAN – manifold for 3 rows of modules
- 001_DCP – Power supply 230V/24V
- 002_CON – Remote control unit
- 003_SEN – Proximity sensor
- Air filter regulator
- Tubes, brackets and air pipes

Note: Machine is integrated using the sensor 003_SEN (included in the kit).

Grid-Lok Gold, 18” modules

Part No.	Description
GHD4718-4	Kit with 4 modules (AX-301 = one module / table)
GHD4718-6	Kit with 6 modules (AX-501 = one module / table)
GHD4718-8	Kit with 8 modules (AX-301 = two modules / table)
GHD4718-12	Kit with 12 modules (AX-501 = two modules / table)
GHD4718-12	Kit with 12 modules (AX-301 = three modules / table)
GHD4718-18	Kit with 18 modules (AX-501 = three modules / table)
GHD4718	Golden HD single module

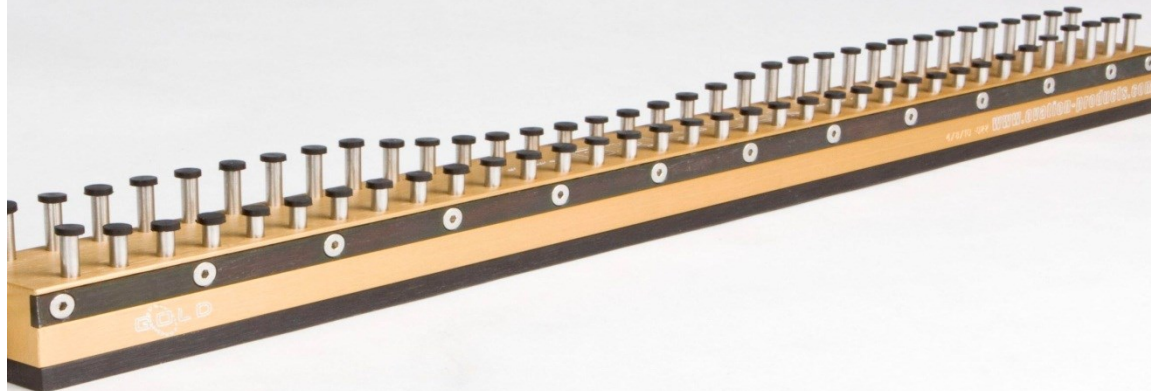

Note: Grid-Lok Silver is not available for this type of machine, due to the very low tooling height (39mm).



Casio 7000-8000 series

Kit content – tech specs

- “n” PCB support modules
 - module length: 14”
 - module width: 32mm
 - module height (pins set): 66mm
 - module height (pins reset): 49.5mm
 - pins: 27
- “n” twin leashes with fittings
- 111_CTL – single table controller
- 006_MAN – 6 station manifold
- 002_CON – Remote control unit
- 001_DCP – Power supply 230V/24V
- Air filter regulator
- Tubes and air pipes

Note: Kit is integrated using 077_SBA sensor, which is not included in the kit.

Grid-Lok Silver, 14” modules

Part No.	Description
GMD6614M	Silver manual single module
GMD6614-0	Conversion kit
GMD6614A-1	Kit with one module
GMD6614A-2	Kit with 2 modules
GMD6614A-3	Kit with 3 modules
GMD6614A	Silver auto single module

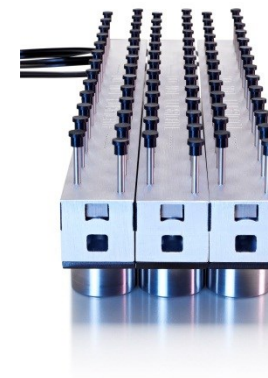

Dima HP110

Kit content – tech specs

- “n” PCB support modules
 - module length: 10”
 - module width: 32mm
 - module height (pins set): 81mm
 - module height (pins reset): 64.5mm
 - pins: 19
- “n” twin leashes with fittings
- 111_CTL – single table controller
- 006_MAN – manifold for 6 modules
- 001_DCP – Power supply 230V/24V
- Air filter regulator
- Tubes and air pipes

Note: Kit is integrated using 077_SBA sensor, which is not included in the kit.

Grid-Lok Silver, 10” modules

Part No.	Description
GMD5310M	Silver manual single module
GMD5310-0	Conversion kit
GMD5310A-1	Kit with one module
GMD5310A-2	Kit with 2 modules
GMD5310A-3	Kit with 3 modules
GMD5310A	Silver auto single module



Fuji NXT M3

Kit content – tech specs

- “n” PCB support modules
 - module length: 10”
 - module width: 25mm
 - module height (pins set): 53mm
 - module height (pins reset): 36.5mm
 - pins: 19
- “n” twin leashes with fittings
- 111_CTL – single table controller
- 001_DCP – Power supply 230V/24V
- Air filter regulator
- Tubes and air pipes

Note: Kit is integrated using 077_SBA sensor, which is not included in the kit.

Grid-Lok Silver, 10” modules

Part No.	Description
GMD5310M	Silver manual single module
GMD5310-0	Conversion kit
GMD5310A-1	Kit with one module
GMD5310A-2	Kit with 2 modules
GMD5310A-3	Kit with 3 modules
GMD5310A	Silver auto single module



Fuji NXT M3 dual lane

Kit content – tech specs

- “n” PCB support modules
 - module length: 10”
 - module width: 25mm
 - module height (pins set): 53mm
 - module height (pins reset): 36.5mm
 - pins: 19
- “n” twin leashes with fittings
- 211_CTL – dual table controller
- 001_DCP – Power supply 230V/24V
- Air filter regulator
- Tubes and air pipes

Note: Kit is integrated using 077_SBA sensors (one for each table), which are not included in the kit.

Grid-Lok Silver, 10” modules

Part No.	Description
GMD5310M	Silver manual single module
GMD5310A2-0	Conversion kit
GMD5310A2-2	Kit with 2 modules (one per each table), dual controller
GMD5310A2-4	Kit with 4 modules (two per each table) , dual controller
GMD5310A2-6	Kit with 6 modules (three per each table), dual controller
GMD5310A	Silver auto single module



Fuji NXT M3 triple lane

Kit content – tech specs

- “n” PCB support modules
 - module length: 10”
 - module width: 25mm
 - module height (pins set): 53mm
 - module height (pins reset): 36.5mm
 - pins: 19
- “n” twin leashes with fittings
- 111_CTL – single controller
- 211_CTL – dual controller
- 001_DCP – Power supply 230V/24V
- Air filter regulator
- Tubes and air pipes

Note: Kit is integrated using 077_SBA sensors (one for each table), which are not included in the kit.

Grid-Lok Silver, 10” modules

Part No.	Description
GMD5310M	Silver manual single module
GMD5310A3-0	Conversion kit
GMD5310A3-3	Kit with 3 modules (one per each table), dual controller
GMD5310A3-6	Kit with 6 modules (two per each table) , dual controller
GMD5310A3-9	Kit with 9 modules (three per each table), dual controller
GMD5310A	Silver auto single module

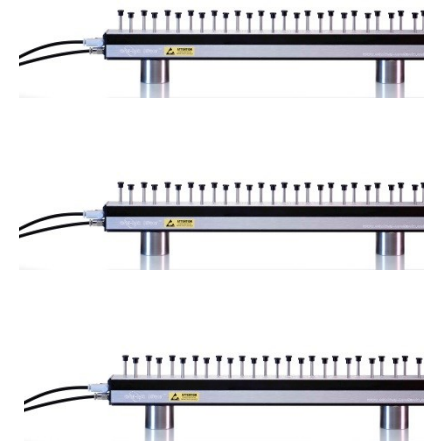

Fuji NXT M6

Kit content – tech specs

- “n” PCB support modules
 - module length: 14”
 - module width: 25mm
 - module height (pins set): 53mm
 - module height (pins reset): 36.5mm
 - pins: 27
- “n” twin leashes with fittings
- 111_CTL – single table controller
- 001_DCP – Power supply 230V/24V
- Air filter regulator
- Tubes and air pipes

Note: Kit is integrated using 077_SBA sensor, which is not included in the kit.

Grid-Lok Silver, 14” modules

Part No.	Description
GMD5314M	Silver manual single module
GMD5314-0	Conversion kit
GMD5314A-1	Kit with one module
GMD5314A-2	Kit with 2 modules
GMD5314A-3	Kit with 3 modules
GMD5314A	Silver auto single module



Fuji NXT M6 dual lane

Kit content – tech specs

- “n” PCB support modules
 - module length: 14”
 - module width: 25mm
 - module height (pins set): 53mm
 - module height (pins reset): 36.5mm
 - pins: 27
- “n” twin leashes with fittings
- 211_CTL – dual table controller
- 001_DCP – Power supply 230V/24V
- Air filter regulator
- Tubes and air pipes

Note: Kit is integrated using 077_SBA sensors (one for each table), which are not included in the kit.

Grid-Lok Silver, 14” modules

Part No.	Description
GMD5314M	Silver manual single module
GMD5314A2-0	Conversion kit
GMD5314A2-2	Kit with 2 modules (one per each table), dual controller
GMD5314A2-4	Kit with 4 modules (two per each table) , dual controller
GMD5314A2-6	Kit with 6 modules (three per each table), dual controller
GMD5314A	Silver auto single module

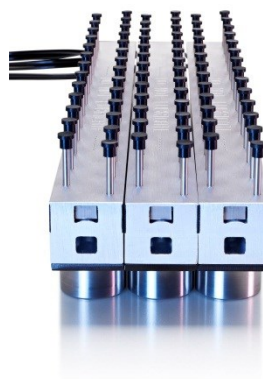

I-Pulse M series

Kit content – tech specs

- “n” PCB support modules
 - module length: 14”
 - module width: 25mm
 - module height (pins set): 70mm
 - module height (pins reset): 53.5mm
 - pins: 27
- “n” twin leashes with fittings
- 111_CTL – single table controller
- 006_MAN – 6 station manifold
- 002_CON – Remote control unit
- 001_DCP – Power supply 230V/24V
- Air filter regulator
- Tubes and air pipes

Note: Kit is integrated using 077_SBA sensor, which is not included in the kit.

Grid-Lok Silver, 14” modules

Part No.	Description
GMD7014M	Silver manual single module
GMD7014-0	Conversion kit
GMD7014A-1	Kit with one module
GMD7014A-2	Kit with 2 modules
GMD7014A-3	Kit with 3 modules
GMD7014A	Silver auto single module



Juki FX1, FX2, KE and JX series

Kit content – tech specs

- “n” PCB support modules
 - module length: 14”
 - module width: 25mm
 - module height (pins set): 97mm
 - module height (pins reset): 80.5mm
 - pins: 27
- “n” twin leashes with fittings
- 111_CTL – single table controller
- 006_MAN – 6 station manifold
- 002_CON – Remote control unit
- 001_DCP – Power supply 230V/24V
- Air filter regulator
- Tubes and air pipes

Note: Kit is integrated using 077_SBA sensor, which is not included in the kit.

Grid-Lok Silver, 14” modules

Part No.	Description
GMD9714M	Silver manual single module
GMD9714-0	Conversion kit
GMD9714A-1	Kit with one module
GMD9714A-2	Kit with 2 modules
GMD9714A-3	Kit with 3 modules
GMD9714A	Silver auto single module



Juki FX-3, FX-3R (machines with two independent tables)

Kit content – tech specs

- “n” PCB support modules
 - module length: 14”
 - module width: 25mm
 - module height (pins set): 97mm
 - module height (pins reset): 80.5mm
 - pins: 27
- “n” twin leashes with fittings
- 211_CTL – dual table controller
- 2 x 006_MAN – 6 station manifolds
- 001_DCP – Power supply 230V/24V
- Air filter regulator
- Tubes and air pipes

Note: Kit is integrated using 077_SBA sensors (one for each table), which are not included in the kit.

Grid-Lok Silver, 14” modules

Part No.	Description
GMD9714M	Silver manual single module
GMD9714A2-0	Conversion kit
GMD9714A2-2	Kit with 2 modules (one per each table), dual controller
GMD9714A2-4	Kit with 4 modules (two per each table) , dual controller
GMD9714A2-6	Kit with 6 modules (three per each table), dual controller
GMD9714A	Silver auto single module



Mimot machines, small table

Kit content – tech specs

- “n” PCB support modules
 - module length: 12”
 - module width: 32mm
 - module height (pins set): 39mm
 - module height (pins reset): 25.5mm
 - pins: 46
- “n” twin leashes with fittings
- 111_CTL – single table controller
- 006_MAN – manifold for 6 modules
- 001_DCP – Power supply 230V/24V
- 002_CON – Remote control unit
- Air filter regulator
- Tubes and air pipes

Note: Machine is integrated using pneumatic input from board clamps.

Grid-Lok Gold, 12” modules

Part No.	Description
GHD3912M-1	Kit with one module
GHD3912M-2	Kit with 2 modules
GHD3912M-3	Kit with 3 modules
GHD3912M-4	Kit with 4 modules
GHD3912M-5	Kit with 5 modules
GHD3912M-6	Kit with 6 modules
GHD3912M	Golden HD single module

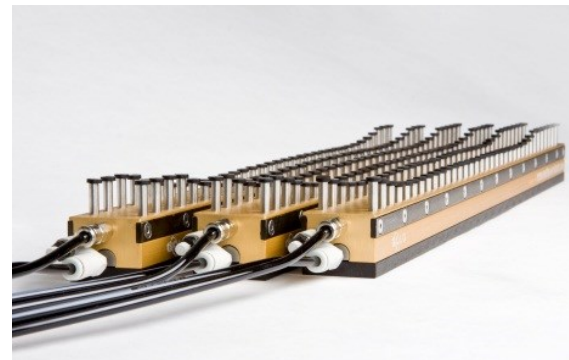

Note: Grid-Lok Silver is not available for this type of machine, due to the very low tooling height (39mm).

Mimot machines, large table

Kit content – tech specs

- “n” PCB support modules
 - module length: 18”
 - module width: 32mm
 - module height (pins set): 39mm
 - module height (pins reset): 25.5mm
 - pins: 70
- “n” twin leashes with fittings
- 111_CTL – single table controller
- 006_MAN – manifold for 6 modules
- 001_DCP – Power supply 230V/24V
- 002_CON – Remote control unit
- Air filter regulator
- Tubes and air pipes

Note: Machine is integrated using pneumatic input from board clamps.

Grid-Lok Gold, 18” modules

Part No.	Description
GHD3918M-1	Kit with one module
GHD3918M-2	Kit with 2 modules
GHD3918M-3	Kit with 3 modules
GHD3918M-4	Kit with 4 modules
GHD3918M-5	Kit with 5 modules
GHD3918M-6	Kit with 6 modules
GHD3918M	Golden HD single module

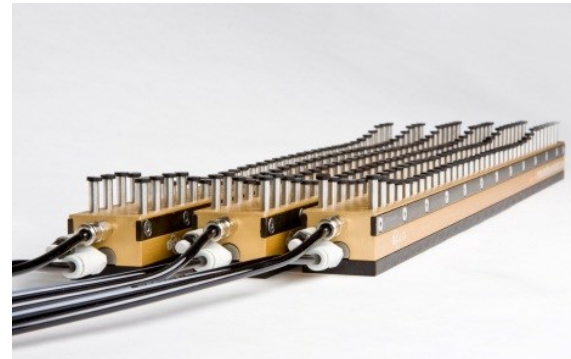

Note: Grid-Lok Silver is not available for this type of machine, due to the very low tooling height (39mm).

Mirae MX-200 single table machines

Kit content – tech specs

- “n” PCB support modules
 - module length: 14”
 - module width: 25mm
 - module height (pins set): 85mm
 - module height (pins reset): 68.5mm
 - pins: 27
- “n” twin leashes with fittings
- 111_CTL – single table controller
- 006_MAN – 6 station manifold
- 002_CON – Remote control unit
- 001_DCP – Power supply 230V/24V
- Air filter regulator
- Tubes and air pipes

Note: Kit is integrated using 077_SBA sensor, which is not included in the kit.

Grid-Lok Silver, 14” modules

Part No.	Description
GMD8514M	Silver manual single module
GMD8514-0	Conversion kit
GMD8514A-1	Kit with one module
GMD8514A-2	Kit with 2 modules
GMD8514A-3	Kit with 3 modules
GMD8514A	Silver auto single module

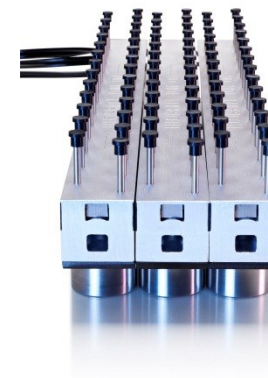

Mirae MX-400 (machines with two independent tables)

Kit content – tech specs

- “n” PCB support modules
 - module length: 14”
 - module width: 25mm
 - module height (pins set): 85mm
 - module height (pins reset): 68.5mm
 - pins: 27
- “n” twin leashes with fittings
- 211_CTL – dual table controller
- 2 x 006_MAN – 6 station manifolds
- 001_DCP – Power supply 230V/24V
- Air filter regulator
- Tubes and air pipes

Note: Kit is integrated using 077_SBA sensors (one for each table), which are not included in the kit.

Grid-Lok Silver, 14” modules

Part No.	Description
GMD8514M	Silver manual single module
GMD8514A2-0	Conversion kit
GMD8514A2-2	Kit with 2 modules (one per each table), dual controller
GMD8514A2-4	Kit with 4 modules (two per each table) , dual controller
GMD8514A2-6	Kit with 6 modules (three per each table), dual controller
GMD8514A	Silver auto single module

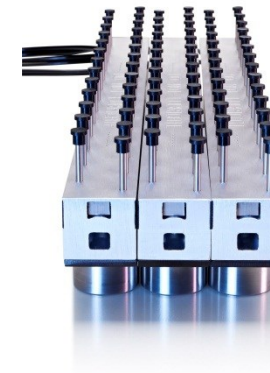

Panasonic DT-401 placement machines

Kit content – tech specs

- “n” PCB support modules
 - module length: 9”
 - module width: 25mm
 - module height (pins set): 75mm
 - module height (pins reset): 58mm
 - pins: 9
- “n” twin leashes with fittings
- 2 x Special Panasonic tables with manifold
- 211_CTL – dual table controller
- 001_DCP – Power supply 230V/24V
- Air filter regulator
- Tubes and air pipes

Note: Kit is integrated using 077_SBA sensors (one for each table), which are not included in the kit.

Grid-Lok Gold, 9” modules, single row

Part No.	Description
GSX7509A2-2	Kit with 2 modules (one per each table), dual controller
GSX7509A2-4	Kit with 4 modules (two per each table) , dual controller
GSX7509A2-6	Kit with 6 modules (three per each table), dual controller
GSX7509	Golden GSX single module



Panasonic CM-402, CM-602 machines

Kit content – tech specs

- “n” PCB support modules
 - module length: 9”
 - module width: 25mm
 - module height (pins set): 75mm
 - module height (pins reset): 58mm
 - pins: 9
- “n” twin leashes with fittings
- 4 x Special Panasonic tables with manifold
- 411_CTL – 4-ways “quad” controller
- 001_DCP – Power supply 230V/24V
- Air filter regulator
- Tubes and air pipes

Note: Kit is integrated using 077_SBA sensors (one for each table), which are not included in the kit.

Grid-Lok Gold, 9” modules, single row

Part No.	Description
GSX7509A4-4	Kit with 4 modules (one per each table), quad controller
GSX7509A4-8	Kit with 8 modules (two per each table), quad controller
GSX7509A4-12	Kit with 12 modules (three per each table), quad controller
GSX7509	Golden GSX single module

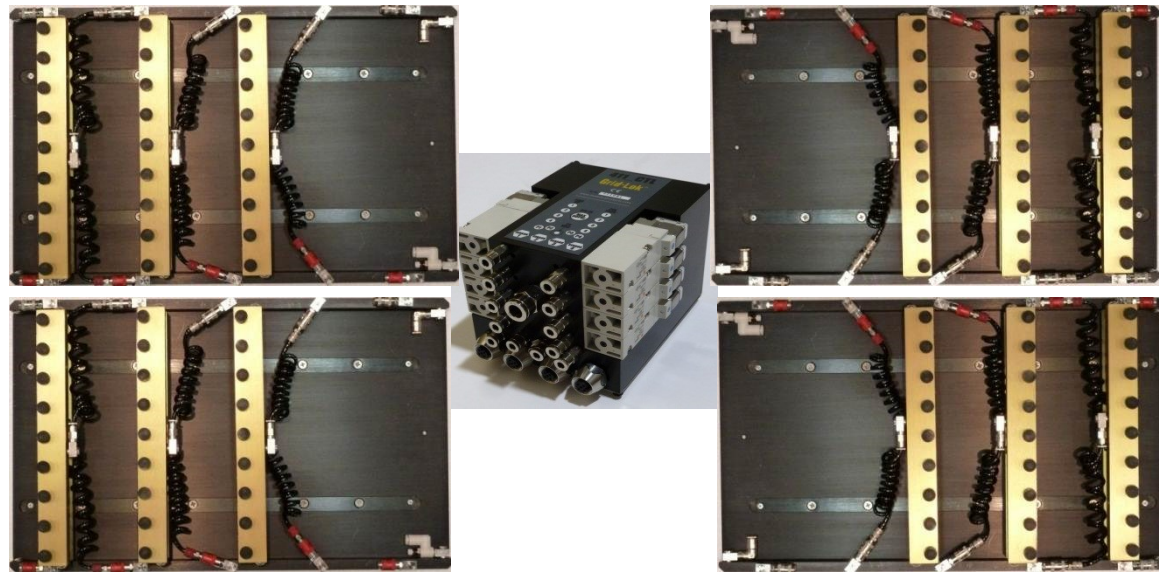

Samsung CP-20, CP-45 machines

Kit content – tech specs

- “n” PCB support modules
 - module length: 14”
 - module width: 25mm
 - module height (pins set): 132mm
 - module height (pins reset): 115.5mm
 - pins: 27
- “n” twin leashes with fittings
- 111_CTL – single table controller
- 006_MAN – 6 station manifold
- 002_CON – Remote control unit
- 001_DCP – Power supply 230V/24V
- Air filter regulator
- Tubes and air pipes

Note: Kit is integrated using 077_SBA sensor, which is not included in the kit.

Grid-Lok Silver, 14” modules

Part No.	Description
GMD1324M	Silver manual single module
GMD1324-0	Conversion kit
GMD1324A-1	Kit with one module
GMD1324A-2	Kit with 2 modules
GMD1324A-3	Kit with 3 modules
GMD1324A	Silver auto single module

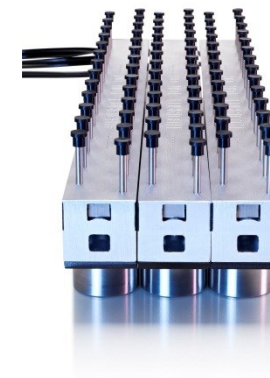

Samsung CP-60 machines

Kit content – tech specs

- “n” PCB support modules
 - module length: 14”
 - module width: 25mm
 - module height (pins set): 93mm
 - module height (pins reset): 76.5mm
 - pins: 27
- “n” twin leashes with fittings
- 111_CTL – single table controller
- 006_MAN – 6 station manifold
- 002_CON – Remote control unit
- 001_DCP – Power supply 230V/24V
- Air filter regulator
- Tubes and air pipes

Note: Kit is integrated using 077_SBA sensor, which is not included in the kit.

Grid-Lok Silver, 14” modules

Part No.	Description
GMD9314M	Silver manual single module
GMD9314-0	Conversion kit
GMD9314A-1	Kit with one module
GMD9314A-2	Kit with 2 modules
GMD9314A-3	Kit with 3 modules
GMD9314A	Silver auto single module

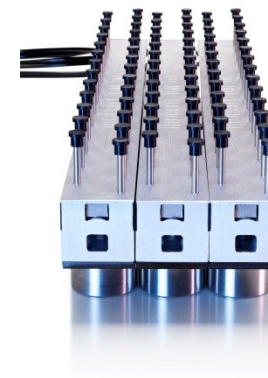

Samsung CP-40 machines

Kit content – tech specs

- “n” PCB support modules
 - module length: 14”
 - module width: 25mm
 - module height (pins set): 66mm
 - module height (pins reset): 49.5mm
 - pins: 27
- “n” twin leashes with fittings
- 111_CTL – single table controller
- 006_MAN – 6 station manifold
- 002_CON – Remote control unit
- 001_DCP – Power supply 230V/24V
- Air filter regulator
- Tubes and air pipes

Note: Kit is integrated using 077_SBA sensor, which is not included in the kit.

Grid-Lok Silver, 14” modules

Part No.	Description
GMD6614M	Silver manual single module
GMD6614-0	Conversion kit
GMD6614A-1	Kit with one module
GMD6614A-2	Kit with 2 modules
GMD6614A-3	Kit with 3 modules
GMD6614A	Silver auto single module

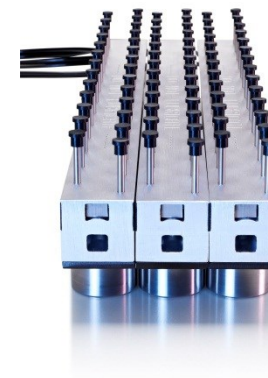

Sanyo TCM placement machines

Kit content – tech specs

- “n” PCB support modules
 - module length: 16”
 - module width: 25mm
 - module height (pins set): 39mm
 - module height (pins reset): 27mm
 - pins: 16
- “n” twin leashes with fittings
- 111_CTL – single table controller
- 006_MAN – manifold for 6 modules
- 001_DCP – Power supply 230V/24V
- 002_CON – Remote control unit
- Air filter regulator
- Tubes and air pipes

Note: Machine is integrated using the 077_SBA sensor, which is not included in the kit.

Grid-Lok Gold, 16” modules, single row

Part No.	Description
GSX3916S-1	Kit with one module
GSX3916S-2	Kit with 2 modules
GSX3916S-3	Kit with 3 modules
GSX3916S-4	Kit with 4 modules
GSX3916S-5	Kit with 5 modules
GSX3916S	Golden GSX single module



Note: Grid-Lok Silver is not available for this type of machine, due to the very low tooling height (39mm).

Universal GX-11S, GC-30S, GX-11D, GI-14D, GC-60D, AC-15S, AC-30S, AI-07S

Kit content – tech specs

- “n” PCB support modules
 - module length: 14”
 - module width: 32mm
 - module height (pins set): 57mm
 - module height (pins reset): 40.5mm
 - pins: 27
- “n” twin leashes with fittings
- 111_CTL – single table controller
- 006_MAN – 6 station manifold
- 002_CON – Remote control unit
- 001_DCP – Power supply 230V/24V
- Air filter regulator
- Tubes and air pipes

Note: Kit is integrated using 077_SBA sensor, which is not included in the kit.

Grid-Lok Silver, 14” modules

Part No.	Description
GMD5714M	Silver manual single module
GMD5714-0	Conversion kit
GMD5714A-1	Kit with one module
GMD5714A-2	Kit with 2 modules
GMD5714A-3	Kit with 3 modules
GMD5714A	Silver auto single module



Universal AC-90T, GC-120Q [machines with two independent tables]

Kit content – tech specs

- “n” PCB support modules
 - module length: 14”
 - module width: 32mm
 - module height (pins set): 57mm
 - module height (pins reset): 40.5mm
 - pins: 27
- “n” twin leashes with fittings
- 211_CTL – 1e table controller
- 006_MAN – 6 station manifold
- 002_CON – Remote control unit
- 001_DCP – Power supply 230V/24V
- Air filter regulator
- Tubes and air pipes

Note: Kit is integrated using 077_SBA sensor, which is not included in the kit.

Grid-Lok Silver, 14” modules

Part No.	Description
GMD5714M	Silver manual single module
GMD5714A2-0	Conversion kit
GMD5714A2-2	Kit with 2 modules (one per each table), dual controller
GMD5714A2-4	Kit with 4 modules (two per each table), dual controller
GMD5714A2-6	Kit with 6 modules (three per each table), dual controller
GMD5714A	Silver auto single module



Yamaha YG88R, YG100R

Kit content – tech specs

- “n” PCB support modules
 - module length: 14”
 - module width: 25mm
 - module height (pins set): 64mm
 - module height (pins reset): 47.5mm
 - pins: 27
- “n” twin leashes with fittings
- 111_CTL – single table controller
- 006_MAN – 6 station manifold
- 002_CON – Remote control unit
- 001_DCP – Power supply 230V/24V
- Air filter regulator
- Tubes and air pipes

Note: Kit is integrated using 077_SBA sensor, which is not included in the kit.

Grid-Lok Silver, 14” modules

Part No.	Description
GMD6414M	Silver manual single module
GMD6414-0	Conversion kit
GMD6414A-1	Kit with one module
GMD6414A-2	Kit with 2 modules
GMD6414A-3	Kit with 3 modules
GMD6414A	Silver auto single module



Yamaha YS12, YS12F, YS12P, YS88, YS100, YG12, YG12F

Kit content – tech specs

- “n” PCB support modules
 - module length: 14”
 - module width: 25mm
 - module height (pins set): 76mm
 - module height (pins reset): 59.5mm
 - pins: 27
- “n” twin leashes with fittings
- 111_CTL – single table controller
- 006_MAN – 6 station manifold
- 002_CON – Remote control unit
- 001_DCP – Power supply 230V/24V
- Air filter regulator
- Tubes and air pipes

Note: Kit is integrated using 077_SBA sensor, which is not included in the kit.

Grid-Lok Silver, 14” modules

Part No.	Description
GMD7614M	Silver manual single module
GMD7614-0	Conversion kit
GMD7614A-1	Kit with one module
GMD7614A-2	Kit with 2 modules
GMD7614A-3	Kit with 3 modules
GMD7614A	Silver auto single module

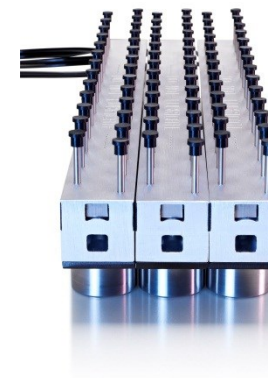

Yamaha YV series

Kit content – tech specs

- “n” PCB support modules
 - module length: 14”
 - module width: 25mm
 - module height (pins set): 68mm
 - module height (pins reset): 51.5mm
 - pins: 27
- “n” twin leashes with fittings
- 111_CTL – single table controller
- 006_MAN – 6 station manifold
- 002_CON – Remote control unit
- 001_DCP – Power supply 230V/24V
- Air filter regulator
- Tubes and air pipes

Note: Kit is integrated using 077_SBA sensor, which is not included in the kit.

Grid-Lok Silver, 14” modules

Part No.	Description
GMD6814M	Silver manual single module
GMD6814-0	Conversion kit
GMD6814A-1	Kit with one module
GMD6814A-2	Kit with 2 modules
GMD6814A-3	Kit with 3 modules
GMD6814A	Silver auto single module

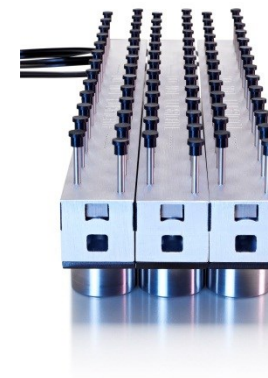

Yamaha YS24 and YS24X

Kit content – tech specs

- “n” PCB support modules – HYBRID (auto modules with pins spring loaded)
 - module length: 254mm (10”)
 - module width: 32mm
 - module height (pins set): 76mm
 - module height (pins reset): 59.5mm
 - pins: 19
- “n” twin leashes with fittings
- 211_CTL – dual table controller
- 001_DCP – Power supply 230V/24V
- Air filter regulator
- Tubes and air pipes
- 2 x 077_SBA optical sensors, for integrating the kit with the machine

Grid-Lok Silver, 10” modules

Part No.	Description
GMD7610M	Silver manual single module
GMD7610AM2-0	Conversion kit
GMD7610AM2-2	Kit with 2 modules (one per each table), dual controller
GMD7610AM2-4	Kit with 4 modules (two per each table) , dual controller
GMD7610AM2-6	Kit with 6 modules (three per each table), dual controller
GMD7610AM	Silver auto single module

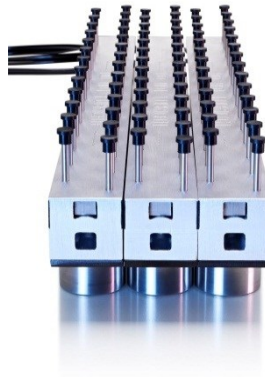

Yamaha YS88 and YS100 machines

Kit content – tech specs

- “n” PCB support modules
 - module length: 9”
 - module width: 25mm
 - module height (pins set): 76mm
 - module height (pins reset): 59mm
 - pins: 9
- “n” twin leashes with fittings
- 211_CTL – dual table controller
- 2 x 006_MAN – 6 station manifolds
- 001_DCP – Power supply 230V/24V
- Air filter regulator
- Tubes and air pipes

Note: Kit is integrated using pneumatic input from board clamps.

Grid-Lok Gold, 9” modules, single row

Part No.	Description
GSX7609AY2-2	Kit with 2 modules (one per each table), dual controller
GSX7609AY2-4	Kit with 4 modules (two per each table) , dual controller
GSX7609AY2-6	Kit with 6 modules (three per each table), dual controller
GSX7609	Golden GSX single module



Q-Lok

Technical specifications

- Replaces the default MPM support system vacuum nest (no over-the-top clamping) with a unit which clamps the PCB and hold it during printing.
- Enables the applicability of Grid-Lok.
- Applicable only for MP UP2000 and AP series.

Part No.	Description
159_GBC	Q-Lok board clamp system
100_QLB	200mm Q-Lok clamp blades set, angled
200_QLB	200mm Q-Lok clamp blades set, flat
300_QLB	300mm Q-Lok clamp blades set, flat



Takaya APT-820-S

Kit content – tech specs

- “n” PCB support modules
 - module length: 12” or 18”
 - module width: 32mm
 - module height (pins set): 42mm
 - module height (pins reset): 28.5mm
 - pins: 70 (gold 18”), 46 (gold 12”)
- “n” twin leashes with fittings
- 111_CTL – single table controller
- 006_MAN – manifold for 6 modules
- 001_DCP – Power supply 230V/24V
- 002_CON – Remote control unit
- Air filter regulator
- Tubes and air pipes

Note: 077_SBA sensor is required, but it’s not included in the kit.

Grid-Lok Gold, 12” modules

Part No.	Description
GHD4212-1	Kit with one module
GHD4212-2	Kit with 2 modules
GHD4212-3	Kit with 3 modules
GHD4212-4	Kit with 4 modules
GHD4212-5	Kit with 5 modules
GHD4212-6	Kit with 6 modules
GHD4212	Golden HD single module



Grid-Lok Gold, 18” modules

Part No.	Description
GHD4218-1	Kit with one module
GHD4218-2	Kit with 2 modules
GHD4218-3	Kit with 3 modules
GHD4218-4	Kit with 4 modules
GHD4218-5	Kit with 5 modules
GHD4218-6	Kit with 6 modules
GHD4218	Golden HD single module

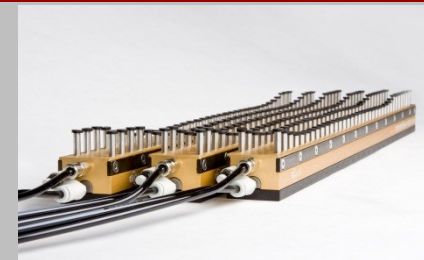

Note: Grid-Lok Silver is not available for this type of machine, due to the very low tooling height (42mm).



Takaya APT-9411-CE-A (50mm special)

Kit content – tech specs

- “n” PCB support modules
 - module length: 12” or 18” (gold), 14” (silver)
 - module width: 32mm
 - module height (pins set): 52mm
 - module height (pins reset): 38.5mm (gold), 36.5mm (silver)
 - pins: 70 (gold 18”), 46 (gold 12”), 27 (silver)
- “n” twin leashes with fittings
- 111_CTL – single table controller
- 006_MAN – manifold for 6 modules
- 001_DCP – Power supply 230V/24V
- 002_CON – Remote control unit
- Air filter regulator
- Tubes and air pipes

Note: Integration is done using pneumatic input from board clamps.

Grid-Lok Gold, 12” modules (recommended)



Grid-Lok Gold, 18” modules (recommended)



Grid-Lok Silver, 14” modules



Part No.	Description
GHD5212-1	Kit with one module
GHD5212-2	Kit with 2 modules
GHD5212-3	Kit with 3 modules
GHD5212-4	Kit with 4 modules
GHD5212-5	Kit with 5 modules
GHD5212-6	Kit with 6 modules
GHD5212	Golden HD single module

Part No.	Description
GHD5218-1	Kit with one module
GHD5218-2	Kit with 2 modules
GHD5218-3	Kit with 3 modules
GHD5218-4	Kit with 4 modules
GHD5218-5	Kit with 5 modules
GHD5218-6	Kit with 6 modules
GHD5218	Golden HD single module

Part No.	Description
GMD5214M	Silver manual single module
GMD5214-0	Conversion kit
GMD5214A-1	Kit with one module
GMD5214A-2	Kit with 2 modules
GMD5214A-3	Kit with 3 modules
GMD5214A-4	Kit with 4 modules
GMD5214A-5	Kit with 5 modules
GMD5214A-6	Kit with 6 modules
GMD5214A	Silver auto single module



Takaya APT-9400-CE, APT-9400-CE-A, APT-9401-CE-A, APT-9411-CE-A

Kit content – tech specs

- “n” PCB support modules
 - module length: 12” or 18” (gold), 14” (silver)
 - module width: 32mm
 - module height (pins set): 62mm
 - module height (pins reset): 41mm (gold), 45.5mm (silver)
 - pins: 70 (gold 18”), 46 (gold 12”), 27 (silver)
- “n” twin leashes with fittings
- 111_CTL – single table controller
- 006_MAN – manifold for 6 modules
- 001_DCP – Power supply 230V/24V
- 002_CON – Remote control unit
- Air filter regulator
- Tubes and air pipes

Note: Integration is done using pneumatic input from board clamps.

Grid-Lok Gold, 12” modules (recommended)



Grid-Lok Gold, 18” modules (recommended)



Grid-Lok Silver, 14” modules



Part No.	Description
GHD6212-1	Kit with one module
GHD6212-2	Kit with 2 modules
GHD6212-3	Kit with 3 modules
GHD6212-4	Kit with 4 modules
GHD6212-5	Kit with 5 modules
GHD6212-6	Kit with 6 modules
GHD6212	Golden HD single module

Part No.	Description
GHD6218-1	Kit with one module
GHD6218-2	Kit with 2 modules
GHD6218-3	Kit with 3 modules
GHD6218-4	Kit with 4 modules
GHD6218-5	Kit with 5 modules
GHD6218-6	Kit with 6 modules
GHD6218	Golden HD single module

Part No.	Description
GMD6214M	Silver manual single module
GMD6214-0	Conversion kit
GMD6214A-1	Kit with one module
GMD6214A-2	Kit with 2 modules
GMD6214A-3	Kit with 3 modules
GMD6214A-4	Kit with 4 modules
GMD6214A-5	Kit with 5 modules
GMD6214A-6	Kit with 6 modules
GMD6214A	Silver auto single module



Takaya APT-9401-CE, APT-9411-CE

Kit content – tech specs

- “n” PCB support modules
 - module length: 12” or 18” (gold), 14” (silver)
 - module width: 32mm
 - module height (pins set): 98mm
 - module height (pins reset): 71mm (gold), 81.5mm (silver)
 - pins: 70 (gold 18”), 46 (gold 12”), 27 (silver)
- “n” twin leashes with fittings
- 111_CTL – single table controller
- 006_MAN – manifold for 6 modules
- 001_DCP – Power supply 230V/24V
- 002_CON – Remote control unit
- Air filter regulator
- Tubes and air pipes

Note: Integration is done using the optical sensor 077_SBA, which is not included in the kit.

Grid-Lok Gold, 12” modules (recommended)



Grid-Lok Gold, 18” modules (recommended)



Grid-Lok Silver, 14” modules



Part No.	Description
GHD9812-1	Kit with one module
GHD9812-2	Kit with 2 modules
GHD9812-3	Kit with 3 modules
GHD9812-4	Kit with 4 modules
GHD9812-5	Kit with 5 modules
GHD9812-6	Kit with 6 modules
GHD9812	Golden HD single module

Part No.	Description
GHD9818-1	Kit with one module
GHD9818-2	Kit with 2 modules
GHD9818-3	Kit with 3 modules
GHD9818-4	Kit with 4 modules
GHD9818-5	Kit with 5 modules
GHD9818-6	Kit with 6 modules
GHD9818	Golden HD single module

Part No.	Description
GMD9814M	Silver manual single module
GMD9814-0	Conversion kit
GMD9814A-1	Kit with one module
GMD9814A-2	Kit with 2 modules
GMD9814A-3	Kit with 3 modules
GMD9814A-4	Kit with 4 modules
GMD9814A-5	Kit with 5 modules
GMD9814A-6	Kit with 6 modules
GMD9814A	Silver auto single module



Takaya APT-8300, APT-8400, APT-8400-CE, APT-8400-CE-A

Kit content – tech specs

- “n” PCB support modules
 - module length: 12” or 18” (gold), 14” (silver)
 - module width: 32mm
 - module height (pins set): 100mm
 - module height (pins reset): 73mm (gold), 83.5mm (silver)
 - pins: 70 (gold 18”), 46 (gold 12”), 27 (silver)
- “n” twin leashes with fittings
- 111_CTL – single table controller
- 006_MAN – manifold for 6 modules
- 001_DCP – Power supply 230V/24V
- 002_CON – Remote control unit
- Air filter regulator
- Tubes and air pipes

Note: Integration is done using the optical sensor 077_SBA, which is not included in the kit.

Grid-Lok Gold, 12” modules (recommended)



Grid-Lok Gold, 18” modules (recommended)



Grid-Lok Silver, 14” modules



Part No.	Description
GHD1002-1	Kit with one module
GHD1002-2	Kit with 2 modules
GHD1002-3	Kit with 3 modules
GHD1002-4	Kit with 4 modules
GHD1002-5	Kit with 5 modules
GHD1002-6	Kit with 6 modules
GHD1002	Golden HD single module

Part No.	Description
GHD1008-1	Kit with one module
GHD1008-2	Kit with 2 modules
GHD1008-3	Kit with 3 modules
GHD1008-4	Kit with 4 modules
GHD1008-5	Kit with 5 modules
GHD1008-6	Kit with 6 modules
GHD1008	Golden HD single module

Part No.	Description
GMD1004M	Silver manual single module
GMD1004-0	Conversion kit
GMD1004A-1	Kit with one module
GMD1004A-2	Kit with 2 modules
GMD1004A-3	Kit with 3 modules
GMD1004A-4	Kit with 4 modules
GMD1004A-5	Kit with 5 modules
GMD1004A-6	Kit with 6 modules
GMD1004A	Silver auto single module



Viscom AOI

Kit content – tech specs

- “n” PCB support modules
 - module length: 18” (gold)
 - module width: 32mm
 - module height (pins set): custom
 - module height (pins reset): custom – 27mm
 - pins: 70
- “n” twin leashes with fittings
- 111_CTL – single table controller
- 006_MAN – manifold for 6 modules
- 001_DCP – Power supply 230V/24V
- 002_CON – Remote control unit
- Air filter regulator
- Tubes and air pipes

Note: Integration is done using the optical sensor 077_SBA.

Grid-Lok Gold, 18” modules

Part No.	Description
GHD8718V-1	Kit with one module
GHD8718V	Golden HD single module

Note: For ordering kits with more than one module, simply add the value of the number of single modules to the above kit’s price.



Top caps



xxx_TIP

Part No.	Description
025_TIP	25 Rubber Compliant Top Caps for GSX
100_TIP	100 Rubber Compliant Top Caps for GSX
025_ETP	25 Rubber Compliant Top Caps (Exp)
025_UTP	25 Universal Compliant Caps for GHD
100_UTP	100 Universal Compliant Caps for GHD
025_TMP	25 Universal Compliant Caps for GMD
100_TMP	100 Universal Compliant Caps for GMD
025_TSP	25 Universal Compliant Caps for GHD 39mm
100_TSP	100 Universal Compliant Caps for GHD 39mm



xxx_TMP

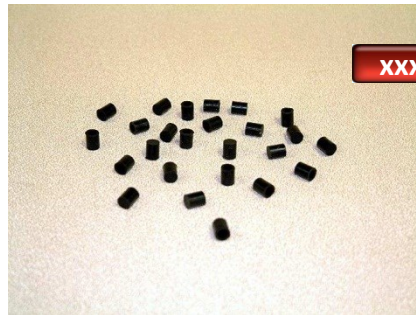

xxx_UTP



xxx_TSP

Pin repair kits



018_PRK



881_PRK



887_PRK



114_PRK



216_PRK



053_PRK



818_PRK

Part No.	Description
018_PRK	DEK, Ekra, Siemens, MPM Pin Repair Kit, 15 pins
881_PRK	81mm HD Grid-Lok Pin Repair Kit, 25 pins
887_PRK	87mm HD Grid-Lok Pin Repair Kit, 25 pins
114_PRK	Grid-Lok Pin Repair Kit (Universal 39mm)
216_PRK	Grid-Lok Pin Repair Kit (39mm)
118_PRK	Grid-Lok Pin Repair Kit (39/42mm)
318_PRK	Grid-Lok Pin Repair Kit (47mm)
009_PRK	Grid-Lok Pin Repair Kit (75mm)
214_PRK	Grid-Lok Pin Repair Kit (66mm)
818_PRK	Grid-Lok HD Pin Repair Kit (39mm), 10 pins
062_PRK	Grid-Lok HD Pin Repair Kit (62mm) , 25 pins
053_PRK	Grid-Lok Silver Pin Repair Kit, 10 pins

Fittings

Part No.	Description
006_SMF	6 Female Silver Quick Connect
006_RMF	6 Female Red Quick Connect
006_AFT	90 Deg. X 1/4" Tube x 1/8" npt
006_FLO	90 Deg. X 1/4" Tube x 1/8" npt Flow Control
018_FLO	Pack of 5 HD Grid_Lok Module Flow Controllers
005_LEA	Twin Tubing w/ fittings, 5 pcs
005_SFT	5/32" Tube x 10-32 Thread Straight Fitting
005_AFT	5/32" Tube x 10-32 Thread 90 Deg. Fitting



006_AFT



005_LEA



005_AFT



006_FLO



006_SMF



006_RMF



005_SFT



018_FLO

Sensors

Part No.	Description
077_SBA	Optical Sensor with Magnetic Base
002_SEN	Grid_Lok Optical Sensor
003_SEN	E3HT-DS3EZ Photoelectric Switch

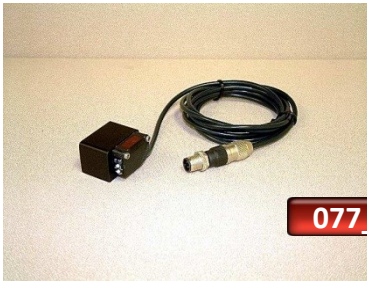

077_SBA



002_SEN



003_SEN

Controllers (boxes and parts)

Part No.	Description
111_CTL	Single Grid-Lok controller
211_CTL	Double Grid-Lok controller
411_CTL	Quadro Grid-Lok controller
103_VAL	Valve inside control box 103_CTL
111_VAL	Valve inside control box 111_CTL
103_PSI	Pressure Sensor for 103_CTL
111_PSI	Pressure Sensor for 111_CTL
103_PCB	Programmed Circuit Board for 103_CTL
111_PCB	Programmed Circuit Board for 111_CTL
211_PCB	Programmed Circuit Board for 211_CTL



111_CTL



211_CTL

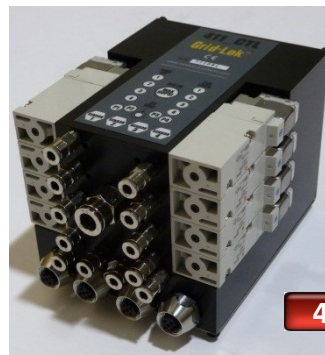

411_CTL



103_CTL

Other spare parts

Part No.	Description
006_MAN	6 Station Manifold Fully Fitted
008_MAN	8 Station Manifold Fully Fitted
002_STO	Magnetic stand off for silver modules - pair
066_BLA	66mm board lifters set
087_BLA	87mm board lifters set
002_CON	Grid-Lok Hand Held Controller (Mark 2)
001_DCP	24 Volt Power Supply
001_RFB	Basic Refurb. Of a Module
518_MAG	18" of Adhesive Magnetic Tape



518_MAG



001_DCP



002_CON



006_MAN

JUKI-GKG stencil printers

Kit content – tech specs

- “n” PCB support modules
 - module length: 12” or 18” (gold), 14” (silver)
 - module width: 32mm
 - module height (pins set): 65mm
 - module height (pins reset): 44mm (gold), 48.5mm (silver)
 - pins: 70 (gold 18”), 46 (gold 12”), 27 (silver)
- “n” twin leashes with fittings
- 111_CTL – single table controller
- 006_MAN – manifold for 6 modules
- 001_DCP – Power supply 230V/24V
- 002_CON – Remote control unit
- Air filter regulator
- Tubes and air pipes

Note: Integration is done using 077_SBA optical sensor.

Grid-Lok Gold, 12” modules (recommended)



Grid-Lok Gold, 18” modules (recommended)



Grid-Lok Silver, 14” modules



Part No.	Description
GHD6512-1	Kit with one module
GHD6512-2	Kit with 2 modules
GHD6512-3	Kit with 3 modules
GHD6512-4	Kit with 4 modules
GHD6512-5	Kit with 5 modules
GHD6512-6	Kit with 6 modules
GHD6512	Golden HD single module

Part No.	Description
GHD6518-1	Kit with one module
GHD6518-2	Kit with 2 modules
GHD6518-3	Kit with 3 modules
GHD6518-4	Kit with 4 modules
GHD6518-5	Kit with 5 modules
GHD6518-6	Kit with 6 modules
GHD6518	Golden HD single module

Part No.	Description
GMD6514M	Silver manual single module
GMD6514-0	Conversion kit
GMD6514A-1	Kit with one module
GMD6514A-2	Kit with 2 modules
GMD6514A-3	Kit with 3 modules
GMD6514A-4	Kit with 4 modules
GMD6514A-5	Kit with 5 modules
GMD6514A-6	Kit with 6 modules
GMD6514A	Silver auto single module



Samsung SM-421 machines

Kit content – tech specs

- “n” PCB support modules
 - module length: 14”
 - module width: 32mm
 - module height (pins set): 132mm
 - module height (pins reset): 115.5mm
 - pins: 27
- “n” twin leashes with fittings
- 111_CTL – single table controller
- 006_MAN – 6 station manifold
- 002_CON – Remote control unit
- 001_DCP – Power supply 230V/24V
- Air filter regulator
- Tubes and air pipes

Note: Kit is integrated using 077_SBA sensor, which is not included in the kit.

Grid-Lok Silver, 14” modules

Part No.	Description
GMD1324M	Silver manual single module
GMD1324-0	Conversion kit
GMD1324A-1	Kit with one module
GMD1324A-2	Kit with 2 modules
GMD1324A-3	Kit with 3 modules
GMD1324A	Silver auto single module

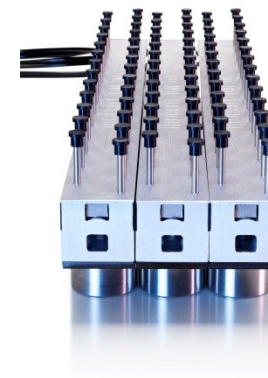

Samsung SM-481 and SM-482 machines

Kit content – tech specs

- “n” PCB support modules
 - module length: 14”
 - module width: 32mm
 - module height (pins set): 134mm
 - module height (pins reset): 117.5mm
 - pins: 27
- “n” twin leashes with fittings
- 111_CTL – single table controller
- 006_MAN – 6 station manifold
- 002_CON – Remote control unit
- 001_DCP – Power supply 230V/24V
- Air filter regulator
- Tubes and air pipes

Note: Kit is integrated using 077_SBA sensor, which is not included in the kit.

Grid-Lok Silver, 14” modules

Part No.	Description
GMD1344M	Silver manual single module
GMD1344-0	Conversion kit
GMD1344A-1	Kit with one module
GMD1344A-2	Kit with 2 modules
GMD1344A-3	Kit with 3 modules
GMD1344A	Silver auto single module

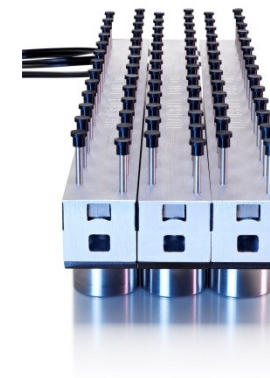

Samsung SM-471 dual machines

Kit content – tech specs

- “n” PCB support modules
 - module length: 14”
 - module width: 32mm
 - module height (pins set): 134mm
 - module height (pins reset): 117.5mm
 - pins: 27
- “n” twin leashes with fittings
- 211_CTL – dual table controller
- 2 x 006_MAN – 6 station manifolds
- 001_DCP – Power supply 230V/24V
- Air filter regulator
- Tubes and air pipes

Note: Kit is integrated using 077_SBA sensors (one for each table), which are not included in the kit.

Grid-Lok Silver, 14” modules

Part No.	Description
GMD1344M	Silver manual single module
GMD1344A2-0	Conversion kit
GMD1344A2-2	Kit with 2 modules (one per each table), dual controller
GMD1344A2-4	Kit with 4 modules (two per each table) , dual controller
GMD1344A2-6	Kit with 6 modules (three per each table), dual controller
GMD1344A	Silver auto single module

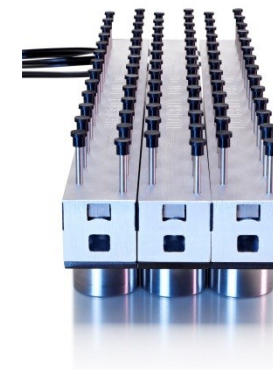
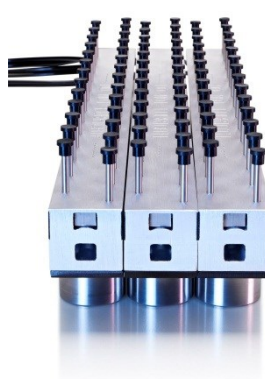

SPEA Flying Probe Grid-Lok selection guide

Click machine type to view the available Grid-Lok options



Grid-Lok Max™
for SPEA flying
probe testers



Itochu-Takaya (tooling height 98mm)

Kit content – tech specs

- “n” PCB support modules
 - module length: 12” or 18” (gold, Max™)
 - module width: 32mm
 - module height (pins set): 98mm
 - module height (pins reset): 58mm
 - pins: 70 (gold 18”), 46 (gold 12”)
- “n” twin leashes with fittings
- 111_CTL – single table controller
- 006_MAN – manifold for 6 modules
- 001_DCP – Power supply 230V/24V
- 002_CON – Remote control unit
- Air filter regulator
- Tubes and air pipes

Note: Integration is done using 077_SBA sensor, which is not included in the kit.

Grid-Lok Max™ 12” modules



Grid-Lok Max™ 18” modules

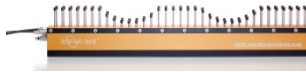

Part No.	Description
GLM9812-1	Kit with one module
GLM9812-2	Kit with 2 modules
GLM9812-3	Kit with 3 modules
GLM9812-4	Kit with 4 modules
GLM9812-5	Kit with 5 modules
GLM9812-6	Kit with 6 modules
GLM9812	Golden HD single module

Part No.	Description
GLM9818-1	Kit with one module
GLM9818-2	Kit with 2 modules
GLM9818-3	Kit with 3 modules
GLM9818-4	Kit with 4 modules
GLM9818-5	Kit with 5 modules
GLM9818-6	Kit with 6 modules
GLM9818	Golden HD single module

Grid-Lok Max™ is a product which addresses the processes where a very high component clearance is required. Its unique component clearance of 40mm increases the flexibility of the Itochu-Takaya flying probe testers which feature a total tooling height of 98mm or more (APT-9401-CE, APT-9411-CE, APT-8300, APT-8400, APT-8400-CE, APT-8400-CE-A).

SPEA (tooling height 110mm)

Kit content – tech specs

- “n” PCB support modules
 - module length: 12” or 18” (gold, Max™)
 - module width: 32mm
 - module height (pins set): 110mm
 - module height (pins reset): 70mm
 - pins: 70 (gold 18”), 46 (gold 12”)
- “n” twin leashes with fittings
- 111_CTL – single table controller
- 006_MAN – manifold for 6 modules
- 001_DCP – Power supply 230V/24V
- 002_CON – Remote control unit
- Air filter regulator
- Tubes and air pipes

Note: Integration is done using 077_SBA sensor, which is not included in the kit.

Grid-Lok Max™ 12” modules



Grid-Lok Max™ 18” modules



Part No.	Description
GLM1012-1	Kit with one module
GLM1012-2	Kit with 2 modules
GLM1012-3	Kit with 3 modules
GLM1012-4	Kit with 4 modules
GLM1012-5	Kit with 5 modules
GLM1012-6	Kit with 6 modules
GLM1012	Golden HD single module

Part No.	Description
GLM1018-1	Kit with one module
GLM1018-2	Kit with 2 modules
GLM1018-3	Kit with 3 modules
GLM1018-4	Kit with 4 modules
GLM1018-5	Kit with 5 modules
GLM1018-6	Kit with 6 modules
GLM1018	Golden HD single module

Grid-Lok Max™ is a product which addresses the processes where a very high component clearance is required. Its unique component clearance of 40mm increases the flexibility of the SPEA flying probe testers which feature a total tooling height of 110mm.



Pin-Lok™ (pin in paste jigs)

Part No.	Description
010_PIP	Pin in paste jig for a 10" silver module
012_PIP	Pin in paste jig for a 12" gold module
014_PIP	Pin in paste jig for a 14" silver module
018_PIP	Pin in paste jig for a 18" gold module



Panasonic NPM-W – single table

Kit content – tech specs

- “n” PCB support modules
 - module length: 14”
 - module width: 32mm
 - module height (pins set): 75mm
 - module height (pins reset): 58.5mm
 - pins: 27
- “n” twin leashes with fittings
- 111_CTL – single table controller
- 001_DCP – Power supply 230V/24V
- Air filter regulator
- Tubes and air pipes
- Hand held remote control

Note: Kit is integrated using the air sensor input from the board clamps of the machine.

Grid-Lok Silver, 14” modules, two rows (Medium Definition)

Part No.	Description
GMD7514M	Silver manual single module
GMD7514A-0	Conversion kit from manual to auto
GMD7514A-1	Kit with one module
GMD7514A-2	Kit with 2 modules
GMD7514A-3	Kit with 3 modules
GMD7514A	Silver auto single module (spare)



Panasonic NPM-D – dual table

Kit content – tech specs

- “n” PCB support modules
 - module length: 14”
 - module width: 32mm
 - module height (pins set): 75mm
 - module height (pins reset): 58.5mm
 - pins: 27
- “n” twin leashes with fittings
- 211_CTL – dual table controller
- 001_DCP – Power supply 230V/24V
- Air filter regulator
- Tubes and air pipes
- The mode buttons are placed on the controller’s panel

Note: Kit is integrated using the air sensor input from the board clamps of the machine.

Grid-Lok Silver, 14” modules, two rows (Medium Definition)

Part No.	Description
GMD7514M	Silver manual single module
GMD75144-0	Conversion kit from manual to auto
GMD7514A2-2	Kit with one module per table (2 in total)
GMD7514A2-4	Kit with 2 modules per table (4 in total)
GMD7514A2-6	Kit with 3 modules per table (6 in total)
GMD7514A	Silver auto single module (spare)

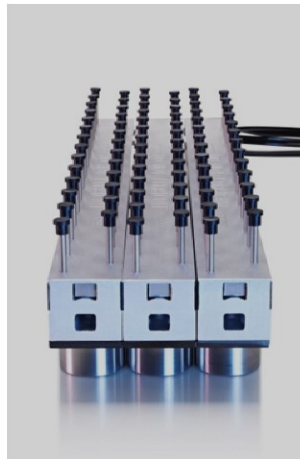

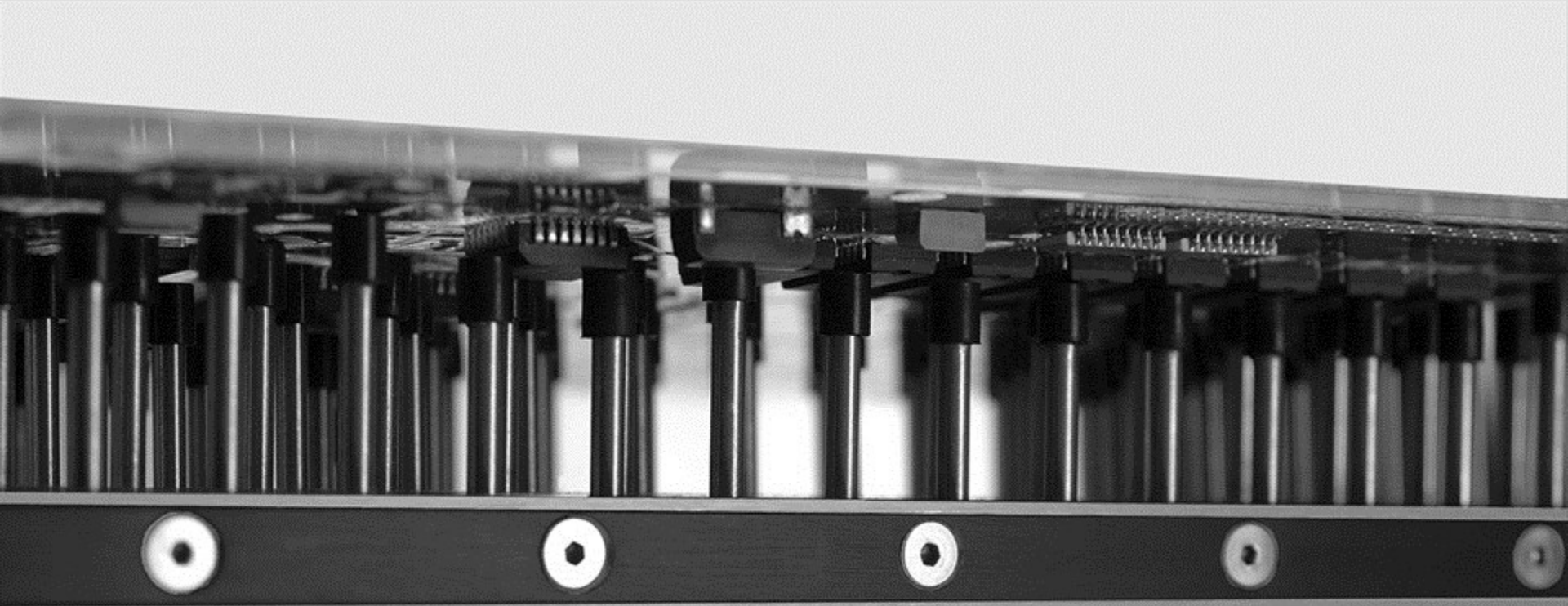

DEK 

ASM 

Grid-Lok

Automated High Density Tooling